



**EVERFORM® SOLID SURFACE  
FABRICATION GUIDE**

.....2-113

# EVERFORM® SOLID SURFACE FABRICATION GUIDE



## TABLE OF CONTENTS

**SCOPE:** This guide outlines the basic fabrication and installation techniques for Everform® Solid Surface.

3	General Safety		
3	Health and Safety Information		
5	Countertops		
5	Kitchens Visual Index	59	Commercial Visual Index   Lobbies
6	Color and Matching	60	Commercial Visual Index   Bathrooms
6	Job Preparation	61	Commercial Visual Index   Restrooms
6	Cutting Everform® Solid Surface Sheets	62	Wall Application
7	Seam Placement	65	Hand Rail
11	Seam Preparation	70	Windowsills
19	Basic Edge Assemblies	72	Knee Walls
25	Custom Profiles	75	Lavatory Tops
26	Undermounted Sinks	80	ADA Standards
30	Installing Cooktops	82	Toilet and Urinal Partitions
32	Countertop Support	86	Toilet Partitions
34	Overhang Support	88	Urinal Partitions
35	Overhang Support Techniques	89	Food Service Countertops
38	Overhang Support (For countertops with cutouts)	95	Table Tops
39	Square Backsplashes	96	Thermoforming
43	Coved Backsplashes	100	Finishing
49	Tiled Backsplashes	100	Finishing Visual Index
52	Bathrooms	104	Finishing dark colors
52	Bathrooms Visual Index	107	Adhesives
53	Undermounted Lavatory Bowls	108	Tools
55	Bath Surrounds	111	Index
57	Shower Surrounds		
58	Commercial		
58	Commercial Visual Index   Nurses Station		

# EVERFORM® SOLID SURFACE FABRICATION GUIDE



## HEALTH AND SAFETY INFORMATION FOR SHEETS AND SHAPED PRODUCTS

### HEALTH HAZARD DATA AND FIRST AID PROCEDURES

Everform® Solid Surface is not hazardous in normal use. However, during fabrication operations (such as sawing, drilling, routing and sanding), dust consisting of cured resin is generated at the cutting face. Maintain adequate ventilation to maintain airborne concentrations of dust below the exposure limits (see exposure control methods below).

**ROUTES OF ENTRY:** The potential routes of entry are inhalation, ingestion, skin contact and eye contact.

#### INHALATION

**NUISANCE DUST:** Overexposure to dust may cause irritation of the respiratory tract. Should this happen, remove affected individual to fresh air. If symptoms persist, consult a physician.

#### INGESTION

**NUISANCE DUST:** May cause direct tissue irritation but is not expected to cause a significant toxic response. Call a physician. DO NOT induce vomiting.

#### SKIN AND EYE

**NUISANCE DUST:** May cause irritation. Wash skin with soap and water. Flush eyes with water for at least 15 minutes. Contact a physician if irritation persists.

### PRECAUTIONS FOR SAFE HANDLING AND USE

Usual Fire and Explosion Hazards: Machining, sawing, routing and/or sanding of this product produces a Class ST-1 dust. Safety precautions (and proper ventilation) as recommended by NFPA-68 for Class ST-1 dusts should be followed to prevent dust from presenting an explosion hazard.

Exposure Control Methods: Provide sufficient ventilation and dust pick-up at saw, sander, drill or router to keep dust level below 10 mg/cubic meter TWA, or provide and make mandatory the wearing of The National Institute for Occupational Safety and Health (NIOSH) approved dust respirators.

Precautions to be taken in Handling and Storage: Safety glasses, gloves and safety shoes should be worn when handling or machining material to prevent cuts and abrasions.

Waste Disposal Method: Scrap material and dust may be disposed of according to applicable Federal, States and local regulations. This product is non-hazardous under Resource Conservation and Recovery Act (RCRA).

Steps To be taken in Case Material is Released or Spilled: This material is non-hazardous. Sweep up/pick up scrap material and place in disposal containers.

For more complete information, request the material safety data sheet (MSDS) for Everform® Solid Surface, which may also be found at [www.formica.com](http://www.formica.com).

### HEALTH HAZARD DATA AND FIRST AID PROCEDURES

#### CAUTION

Everform® Solid Surface seaming adhesive contains separate acrylic resin and benzol peroxide. The hardener may cause irritation to skin, eyes, nose and throat and may even cause an allergic skin reaction.

#### ROUTES OF EXPOSURE:

**SKIN:** May cause irritation and sensitization.

**EYES:** Liquid and vapors cause moderate irritation (burning sensation, tearing, redness, swelling).

**INHALATION:** High concentration is irritant to respiratory tract and may cause dizziness, headache and anaesthetic effects.

**INGESTION:** Causes irritation, a burning sensation of the mouth, throat and gastrointestinal tract and abdominal pain.

**CHRONIC OVEREXPOSURE:** Prolonged exposure may lead to kidney, lung and liver disease. Not likely to cause cancer. Not believed to represent a carcinogenic or mutagenic hazard.

**MEDICAL CONDITION:** Pre-existing eye and skin diseases.

#### OTHER EFFECTS

**MMA:** Developmental toxicity observed in animal tests, but only at levels toxic to the mother. MMA is reported to impair human olfactory function.

### EMERGENCY AND FIRST AID PROCEDURES:

**SKIN:** Immediately remove contaminated clothing and excess contaminant. Flush skin with water. Wash thoroughly with warm water and soap. Consult a physician if irritation develops.

**EYES:** Flush eye with clean water for at least 15 minutes while gently holding eyelids open. Get immediate medical attention.

**INHALATION:** Remove patient to fresh air. Administer oxygen if breathing is difficult. Get medical attention if symptoms persist.

**INGESTION:** Do NOT induce vomiting. Give two glasses of water to dilute if patient is conscious. Get medical attention.

### SPECIAL HEALTH EFFECTS

Inhalation may cause eye, nose and throat irritation. May also cause dizziness, headaches and anaesthetic effects.

### HANDLING AND STORAGE DISPOSAL PROCEDURES

Acrylic resin and hardener when disposed of in liquid state are hazardous waste, but when mixed and polymerized are non-hazardous solid waste. Dispose of unused seaming adhesives by mixing components. Allow the mixture to solidify and then dispose of in accordance with local regulations for industrial waste.

# EVERFORM® SOLID SURFACE FABRICATION GUIDE



## HEALTH AND SAFETY INFORMATION FOR SHEETS AND SHAPED PRODUCTS

### EXPOSURE CONTROLS

#### ENGINEERING CONTROLS

**VENTILATION:** Use ventilation that is adequate to keep employee exposure to airborne concentrations below exposure limits.

**OTHER ENGINEERING CONTROLS:** Keep container tightly closed. Observe label precautions. Have emergency eye wash and safety shower present. Personal protective equipment

**EYE AND FACE PROTECTION:** Wear safety glasses. Wear coverall chemical splash goggles and face shield when eye and face contact is possible.

**SKIN PROTECTION:** Wear impervious butyl rubber clothing as appropriate to prevent contact.

**RESPIRATORY PROTECTION:** A NIOSH/MSHA air purifying respirator with an organic vapor cartridge may be permissible, but use a positive pressure air supplied respirator if there is any potential for uncontrolled release, or unknown exposure levels.

WARNING! Flammable. **EYE, SKIN AND RESPIRATORY IRRITANT.**

*For more information, request the material safety data sheet, which may also be found at [www.formica.com](http://www.formica.com).*

### HEALTH HAZARD DATA AND FIRST AID PROCEDURES

#### CAUTION

Everform® Solid Surface seaming adhesive contains separate acrylic resin and benzol peroxide. The hardener may cause irritation to skin, eyes, nose and throat and may even cause an allergic skin reaction.

#### ROUTES OF EXPOSURE

**SKIN:** Mild irritant. May cause allergic skin reaction and possible sensitization. Low hazard for usual industrial handling or commercial handling by trained personnel.

**EYES:** Irritant, may cause tearing. Low hazard for usual industrial handling or commercial handling by trained personnel.

**INHALATION:** High vapor concentrations are irritating to nose, throat, lungs and eyes. High vapor concentrations may cause dizziness or headaches.

**INGESTION:** Causes irritation, a burning sensation of the mouth, throat and gastrointestinal tract and abdominal pain.

**CHRONIC OVEREXPOSURE:** Prolonged or repeated skin contact may cause sensitization on later exposure.

**MEDICAL CONDITION:** Pre-existing skin or respiratory diseases.

**OTHER EFFECTS:** None known.

### EMERGENCY AND FIRST AID PROCEDURES

**SKIN:** Immediately remove contaminated clothing and excess contaminant. Flush skin with water. Wash thoroughly with warm water and soap. Consult a physician if irritation develops.

**EYES:** Flush eye with clean water for at least 15 minutes while gently holding eyelids open. Get immediate medical attention.

**INHALATION:** Remove patient to fresh air. Administer oxygen if breathing is difficult. Get medical attention if symptoms persist.

**INGESTION:** Do NOT induce vomiting. Get medical attention.

### SPECIAL HEALTH EFFECTS

Inhalation may cause eye, nose and throat irritation. May also cause dizziness, headaches and anaesthetic effects.

### HANDLING AND STORAGE DISPOSAL PROCEDURES

Acrylic resin and hardener when disposed of in liquid state are hazardous waste, but when mixed and polymerized are non-hazardous solid waste. Dispose of unused seaming adhesives by mixing components. Allow the mixture to solidify and then dispose of in accordance with local regulations for industrial waste.

### EXPOSURE CONTROLS

#### ENGINEERING CONTROLS

**VENTILATION:** Good general ventilation (typically 10 air changes per hour) should be used. Ventilation rates should be matched to conditions. Use process enclosures, local exhaust ventilation or other engineering controls to maintain airborne levels below recommended exposure limits.

**OTHER ENGINEERING CONTROLS:** Recommended decontamination facilities: eye, bath, washing facilities. Personal protective equipment

**EYE AND FACE PROTECTION:** It is a good industrial hygiene practice to minimize eye contact and wear safety glasses or goggles.

**SKIN PROTECTION:** It is a good industrial hygiene practice to minimize skin contact and use chemical resistant gloves.

**RESPIRATORY PROTECTION:** If engineering controls do not maintain airborne concentrations below recommended exposure limits, an approved respirator must be worn. Respirator type: mist. If respirators are used, a program should be instituted to assure compliance with OSHA Standard 29 CFR 1910.134.

WARNING! Flammable. **EYE, SKIN AND RESPIRATORY IRRITANT.**

*For more information, request the material safety data sheet, which may also be found at [www.formica.com](http://www.formica.com).*

# EVERFORM® SOLID SURFACE FABRICATION GUIDE



## KITCHENS VISUAL INDEX

COUNTERTOPS

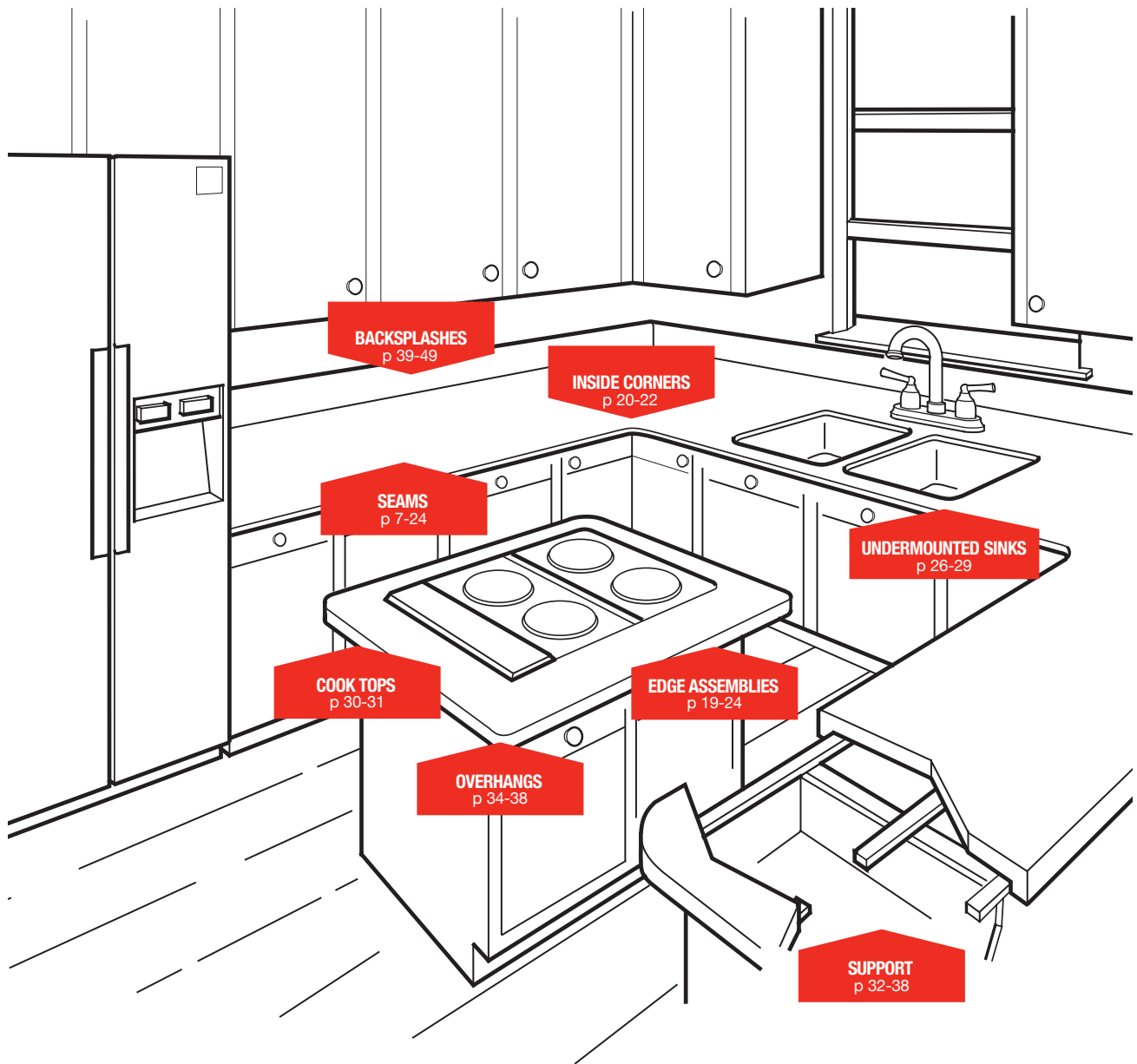

# EVERFORM® SOLID SURFACE FABRICATION GUIDE



## KITCHENS

### COLOR AND MATCHING SHEETS

Every sheet has the batch information printed along the side of the sheet. **When ordering multiple sheets to be seamed, be sure that sheets come from the same batch.** Notify the distributor of this request when ordering. Sheets from different batches will not match.

Copies of labels from the sheets should be attached to job files. The color match number will be required to prove the sheets were color matched in case there is a color match problem during fabrication.

**It is required that the protective films be removed to check for color match compatibility before fabricating. To do this, butt the sheets to be seamed together and visually inspect under good lighting. Also, inspect each sheet for defects and shipping or handling damage. It is up to the fabricator to ensure acceptable color consistency between sheets.**

When the installation is finished, provide the homeowner with a sizeable piece (e.g., sink or stove cutout, off-fall, etc.) of extra matching material. This assures that a matching piece will be available if later repairs are needed.

### JOB PREPARATION MEASURING, TEMPLATING AND SIZING UP THE JOB

Determine the access route to be used for delivering the fabricated top or top sections to the installation site. Take into consideration potential trouble spots such as those presented by corners, hallways, doorways, stairways, ceilings, elevators, etc. Make the necessary measurements of those areas and adjust the fabricated sizes accordingly.

Look for tops, or portions of tops, that are to be fitted between end walls, mullions, etc. These must be undersized sufficiently to avoid binding or stresses caused by thermally induced movement. For normal conditions, where the temperature is not expected to increase more than 50°F (10°C) above the ambient, the top should be undersized about 1/8 in. (3mm) per 10 ft. (304cm) of length. Even greater temperature increases can be expected in glassed, in areas that have southern exposure. Under these conditions, temperatures can climb 65°-70°F (18°-21°C) above the ambient. Tops positioned between end walls, under this condition, must be undersized even more, e.g. 3/16-1/4 in. (5-6mm) per 10 ft. (304cm) of length.

Check the cabinets to make sure they are even, level, securely fastened together and properly anchored to the wall. There should not be out-of-level, high or low sections greater than 1/8 in. (3mm) in 10 feet when a level and straightedge is spanned over the top of the cabinets in various places. If any of these problems exist, make the necessary changes before installing the Everform® Solid Surface top.

Inspect the cabinetry for structural integrity. Not only must it be sturdy enough to support the top, but it must also withstand additional loading from appliances, sinks full of water, someone standing or sitting on it, etc. Areas of particular concern are corner cabinets (front, center and back sections), sink cabinets, cabinets

on either side of slide-in stoves, etc. If weak areas are found, make the necessary structural changes before installing the top.

Dust covers in cabinets can act like underlayment or a solid substrate. Solid topped cabinets, corner cabinets and lazy-susan cabinets must be ventilated to prevent air from being trapped. The top of the cabinet must be cut out as much as possible without hurting the integrity of the cabinet. This will allow heat to dissipate into the cabinet.

Dimensions of small straight tops can generally be determined by simply measuring the cabinets and adding the necessary overhangs. For larger and more complicated tops with seams, cutouts, angled and contoured sections, etc., it is suggested that a template be made.

Templates are generally made from joined sections of thin luan plywood, MDF, cardboard or particleboard. These are scribed and fitted, where necessary, to back walls, corners, etc. and then butted or overlapped to cover the entire cabinet structure. Once these sections are positioned, all template junctions and joints are either securely fastened together or marked for exact repositioning.

Another technique is to outline the cabinet configuration with 2-3 in. (50-76mm) wide strips of thin luan. These are then securely fastened together with hot melt adhesive and stabilized with cross bracing.

With the template in place, trace an outline of the cabinet fronts, inside perimeters for cabinets receiving drop-in ranges and kitchen sinks, etc. directly onto the underside of the template. Other important details, such as locations for windows, doors, outlets and dishwashers can also be marked directly onto the template.

The finished template can then be taken to the shop and re-assembled for use as a pattern. Tops fabricated from well-made templates need little or no fitting adjustments during installation.

### CUTTING EVERFORM® SOLID SURFACE SHEETS

Everform® Solid Surface sheets can be cut into smaller sections with conventional table, panel and hand-held circular saws equipped with tungsten carbide tipped blades. Since sawn edges are generally too rough for seaming, all pieces should be oversized to allow for further trimming during fabrication.

Recommendations for cutting Everform® Solid Surface sheets on different types of saws are as follows:

**HAND-HELD CIRCULAR SAWS:** Use a 24-40 tooth tungsten carbide tipped blade having a triple chip or alternate bevel configuration. Guide the saw along a clamped straight edge with the blade set about 1 in. (25mm) below the material. Cut at a slow to medium feed rate.

**TABLE SAWS:** Use a triple chip C-4 or C-5 tungsten carbide tipped blade having a -5° to +15° hook angle and a blade stiffener collar, positioned on the outside of the blade [e.g. 10 in. (254mm) dia. with 40-72 teeth and a 6 in. (152mm) blade stiffener]. A good quality fence, set parallel to the blade, is required for the best cuts. Cut face-up, at a medium feed rate, with the blade set about 1 in. (25mm) above the surface.

# EVERFORM® SOLID SURFACE FABRICATION GUIDE



## KITCHENS

**PANEL SAWS:** Use a triple chip C-4 or C-5 tungsten carbide tipped blade having a 0° to -5° hook angle and 60-100 teeth on a 12 in. (304mm) blade. Panel saws requiring manual feed can be fed at a medium speed. Automated panel saws should be slowed down to accommodate the increased density of solid surfacing material. Cut with the face up.

Curved cuts for inside and outside corners, contoured edges, semi-circles for islands and peninsulas, etc. can be made with a router, saber or band saw. Saber or band saw cuts must be oversized by  $\frac{1}{8}$  -  $\frac{1}{4}$  in. (3-6mm) to allow for trimming with a router. Blade and cutting recommendations for each are as follows:

**SABER SAWS:** Use a bi-metal, up-stroke cutting blade with 10-14 teeth per inch. Cut at a slow rate, holding the saw firmly on the material to avoid jumping or hammering, which can bruise the surface and cause small fractures along the edge of the cut. Make all cuts  $\frac{1}{8}$  in. (3mm) or more oversized. Rout all edges during fabrication operations or before installation.

Saber saws equipped with the variable speed and orbital cutting action are preferred. Straight and large curved cuts are best made with the saw set at full speed with maximum orbital action. For small curves, the saw must be set for no orbital blade action to avoid binding.

**BAND SAWS:** Use a  $\frac{1}{4}$ - $\frac{1}{2}$  in. (6-12mm) wide bi-metal blade having 10 - 14 teeth per inch. Set the blade speed at the setting for nonferrous metals. Cut at a slow feed rate. Do not force.

## SEAM PLACEMENT

### DECK SEAM PLACEMENT

Careful planning for the proper placement and limited use of seams is an important consideration when laying out a countertop. Besides requiring additional materials and fabrication time, seamed areas are a little weaker than unseamed sections and must be placed only in low stress areas for best performance.

Do not place or run deck seams directly into an inside corner. Seams in "L" and "U" tops must be offset at least 1 in. (25mm) or more away from the radius in the inside corners. Typically, on a 25 in. (635mm) wide top, seams may be easily offset by 5 in. (127mm) when using 30 in. (762mm) or 11 in. (279mm) for 36 in. (914mm) wide sheets, respectively.

Offset seams at least 3 in. (76mm) or more away from the outer edges of undermounted Everform® Solid Surface sinks or bowls. Do not place seams within the sink or bowl area.

In addition, seams must also be offset at least 3 in. (76mm) or more away from cutouts for drop-in or undermount sinks made with materials other than Everform® Solid Surface.

Deck seams must also be offset at least 3 in. (76mm) or more from the outside of cutouts for drop-in or slide-in ranges, stove tops or other heat producing units. Do not allow seams to intersect cutouts for any heat producing unit that includes dishwashers.

Seams, when necessary for fabricating extra wide islands or peninsulas, must not be positioned directly along the supporting cabinet frame having a cantilever or overhang section. Offset seams in this area 3 in. (76mm) or more into the cabinet or out into the cantilever section.

Commercial or residential countertop sections, in excess of 24 lineal feet, will require a flexible joint to accommodate the potential dimensional movement. In food service applications, this can often be coordinated with the flexible joint required between hot and cold sections.

### DROP EDGE SEAM PLACEMENT

Joints in drop edge build-ups must be offset at least 1 in. (25mm) or more away from inside corners and deck seams. Butt joints in alternate layers of sandwiched edge build-ups should also be staggered by 1 in. (25mm) or more for maximum handling strength and performance under load. Additionally, position any butt joints that may be necessary in the bottom layer of a sandwich edge build-up, away from the center of long tops or large "L" or "U" sections for maximum handling strength.

For increased strength, drop edge joints can be angled as illustrated. Joints of this type are more resistant to downward applied loads and flexing than those that are butted at a 90° angle.

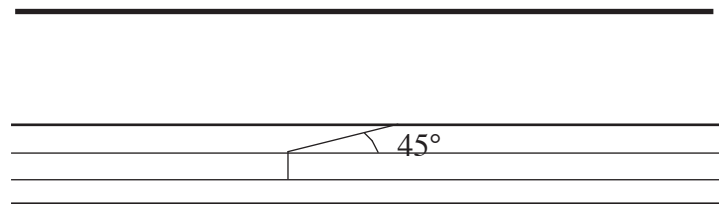

# EVERFORM® SOLID SURFACE FABRICATION GUIDE



## SEAM PLACEMENT FOR INSIDE CORNERS ON “L” OR “U” TOPS

### 1. MEASURE OUT DESIRED CORNER.

Cut out corner.

- Seam must be off-set at least 1 in. (25mm) from the radius in the inside corner.
- Minimum inside corner radius must be ½ in. (12.5mm) or larger.

TYPICAL CUTTING LAYOUT FOR 36 IN. (914MM) SHEETS

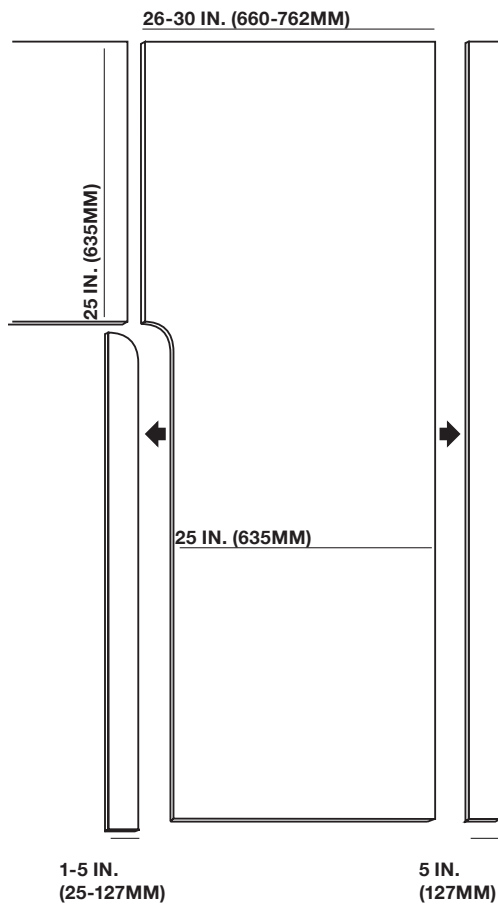

TYPICAL CUTTING LAYOUT FOR 30 IN. (762MM) SHEETS

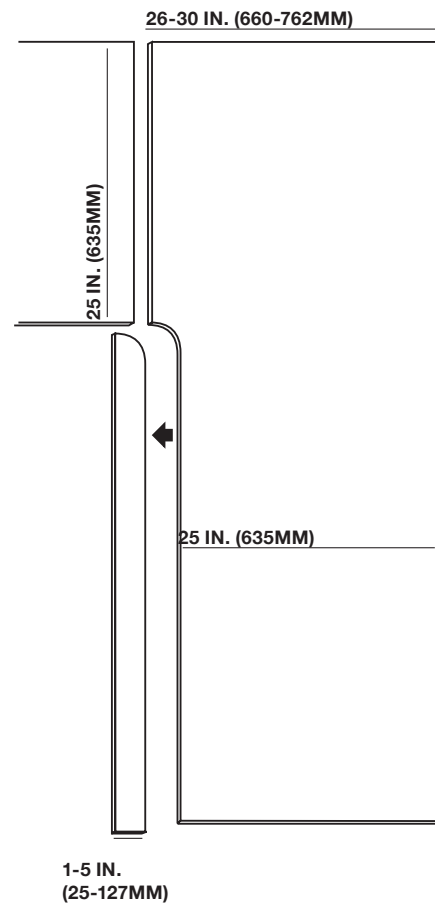



# EVERFORM® SOLID SURFACE FABRICATION GUIDE



## SEAM PLACEMENT

NEAR SINKS OR DROP-IN RANGES IN STANDARD POSITIONS

### NEAR SINKS OR DROP-IN RANGES IN STANDARD POSITIONS

1. Position seams no closer than 3 in. (76mm) from sinks or cut-outs for heat producing units.

- Do not allow seams to intersect cutout areas.

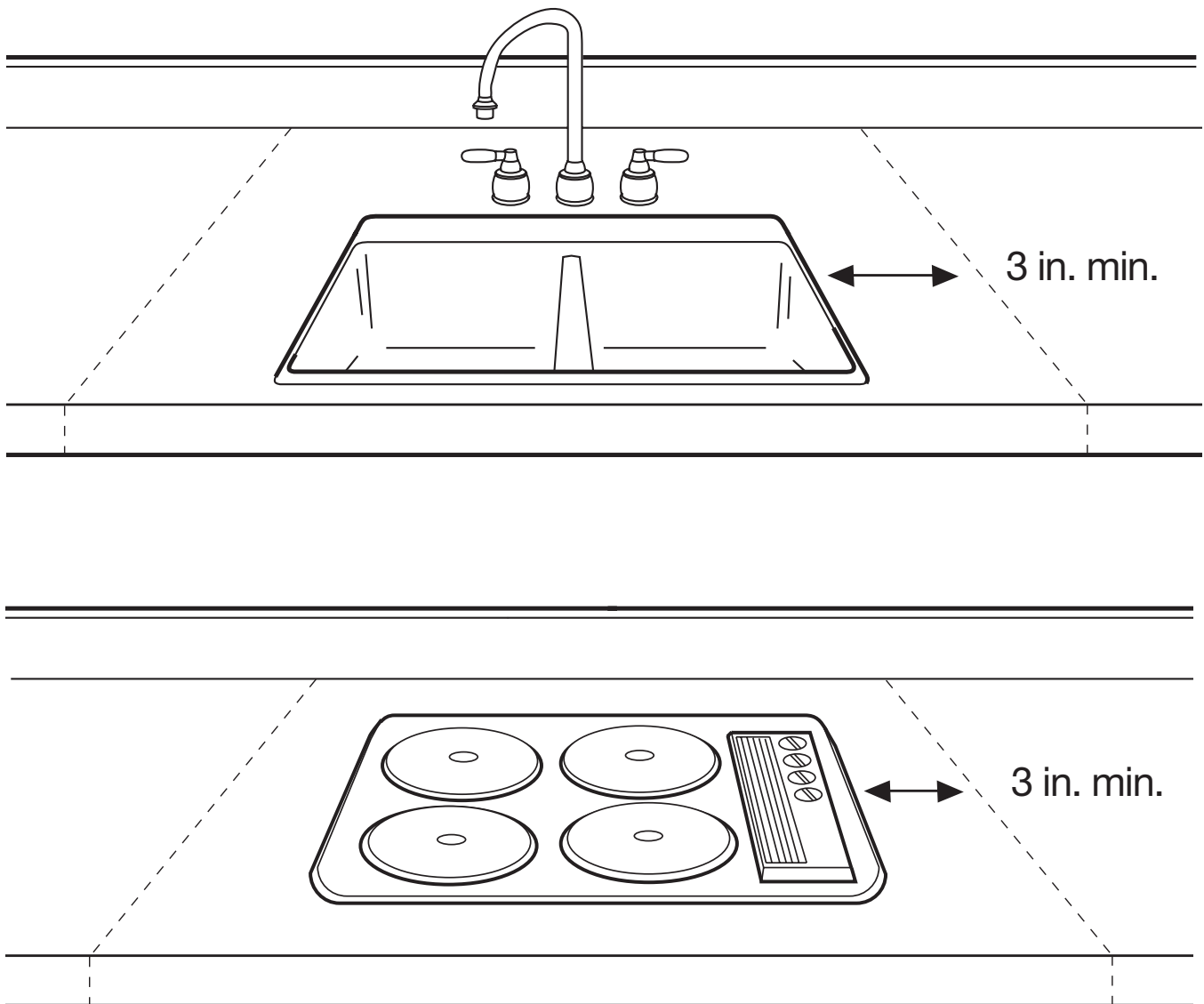

# EVERFORM® SOLID SURFACE FABRICATION GUIDE



## SEAM PLACEMENT

### NEAR CORNER SINKS OR DROP-IN RANGES

#### 1. Measure out full sheet for sink or drop-in range placement.

- Do not place seams within sink or drop-in range cutout area.
- Assemble top as illustrated.

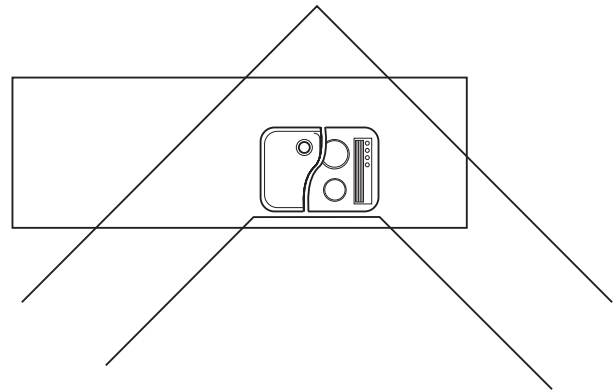

#### 2. Cut out front of counter.

- Cut ends of corner sheet at 45° angles.
- Keep seams 1 in. (25mm) or more away from the radius in the inside corners.
- Minimum inside corner radius must be ½ in. (12.5mm) or larger.
- Keep seams 3 in. (76mm) or more away from drop-in range or sink cut-outs.

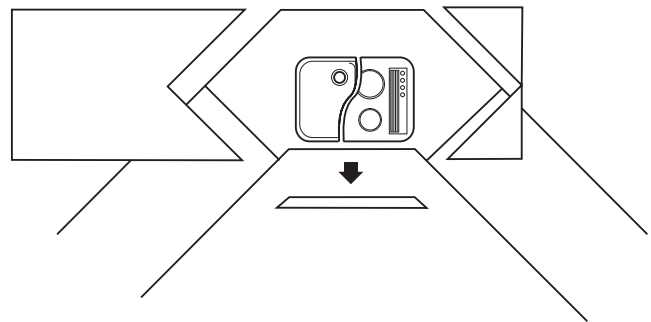

#### 3. Cut out a triangular section for back corner from excess material

- Mirror image rout and seam into place.

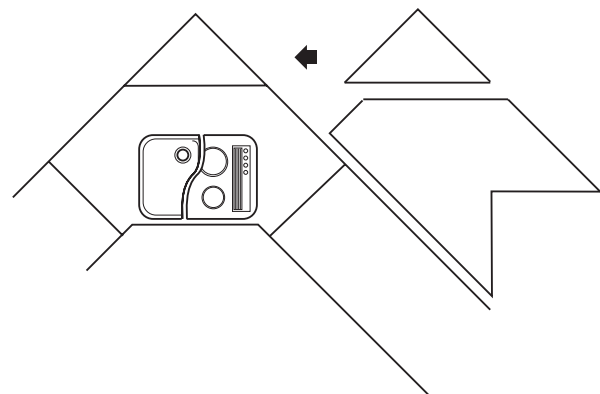

# EVERFORM® SOLID SURFACE FABRICATION GUIDE



## SEAM PREPARATION SHOP SEAMS

### 1. Clamp and mirror image rout seam using a seam routing fixture.

- Use a ½ in. (12.5mm) wide, 2 flute straight carbide cutter with a ½ in. (12.5mm) shank.
- Gap about ⅜ in. (9mm) or less.
- Router must be 1½ HP or larger with ½ in. (12.5mm) collet.

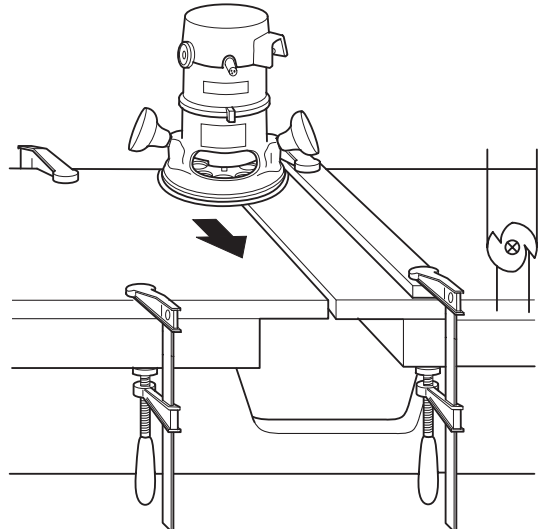

### 2. After routing, check seam for tight fit by butting together.

- Re-rout if necessary.

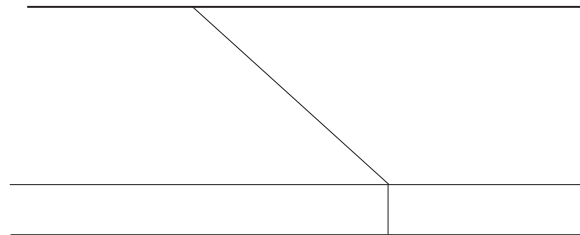

### 3. Clean with denatured alcohol and a clean white rag.

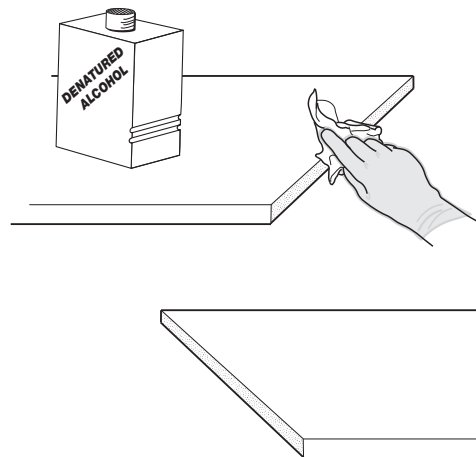

# EVERFORM® SOLID SURFACE FABRICATION GUIDE



## SEAM PREPARATION SHOP SEAMS

### 4. Tape off supporting surface under seam with clear packaging tape.

- Center sheets to be joined over tape with a  $\frac{1}{8}$  in. (3mm) gap.

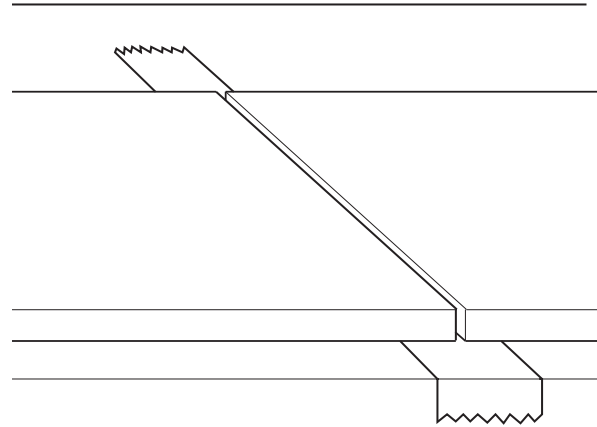

### 5. Clean and adhere wood blocks with hot melt adhesive.

- Blocks should be approximately 2 ½ in. x 4 in. x ¼ in. (63mm x 102mm x 20mm).

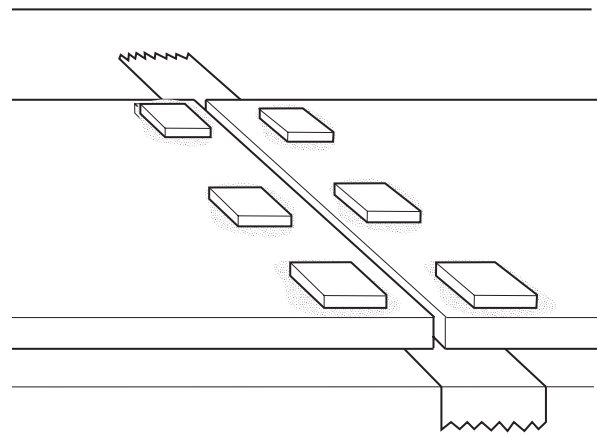

### 6. Fill gap with Everform® Solid Surface seaming adhesive of appropriate color.

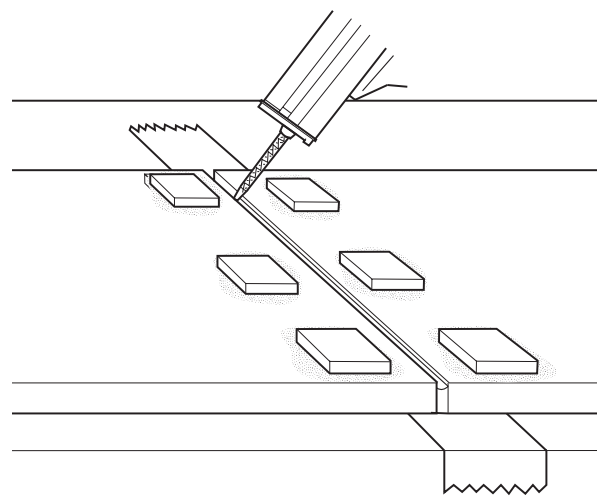

# EVERFORM® SOLID SURFACE FABRICATION GUIDE



## SEAM PREPARATION SHOP SEAMS

### 7. Push joint together and apply firm, clamping pressure.

- Excess adhesive will squeeze out. Do not remove excess.
- Do not over tighten.

**NOTE:** After drawing seams together DO NOT tap down with hammer or device. Disturbing the seam at this point will cause weakness and potential failure. A good dry fit will prevent excess sanding due to an unlevel joint.

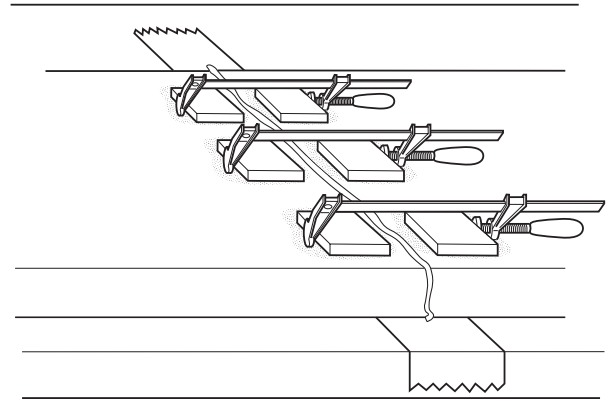

### 8. After adhesive sets (about 45 mins.) remove clamps and wood blocks.

- To remove wood blocks, flood with alcohol. Wait a few minutes and then pry off with a wood chisel.
- Protect the surface with laminate sample under chisel.
- Any residual hot melt adhesive can be removed from surface with a sharp chisel having rounded corners to avoid gouging.

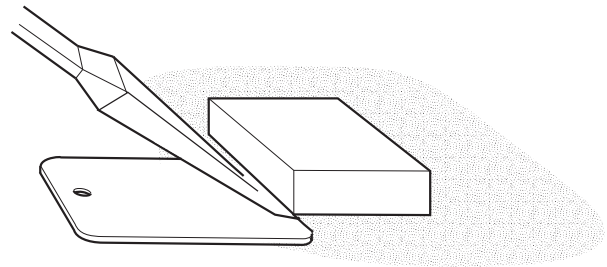

### 9. Remove adhesive bead using a router with a ski base and a flat bottom cutter set just above surface.

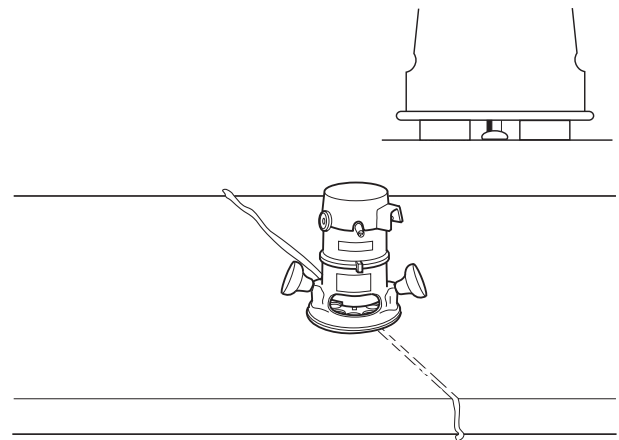

# EVERFORM® SOLID SURFACE FABRICATION GUIDE



## SEAM PREPARATION

### SHOP SEAMS

**10. Use a stiff base random-orbital sander with 100 to 120-grit sandpaper to remove remaining adhesive and to level out seam.**

- Final finishing is normally done after final fabrication steps are completed.

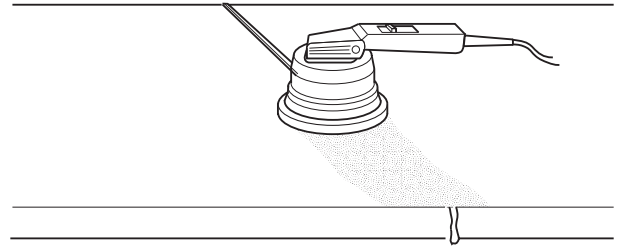

**11. Flip countertop over, exposing back side of seam.**

- Level joint with a stiff base random-orbital sander equipped with a 100-120 grit aluminum oxide sanding disk.

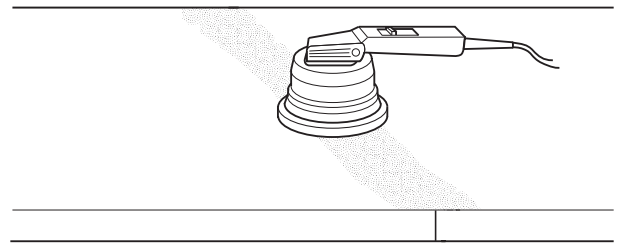

**12. Bond a seam reinforcement\* strip fabricated from ½ in. Everform® Solid Surface to the backside with the seaming adhesive. Center strip over seam.**

- The strip should be 3-4 in. (76-102mm) wide and have a 45° chamfer on each side.
- Butt reinforcement strip up against drop edge for additional strength.

\* Full length seam reinforcement is required for all residential and commercial food service countertops, to increase heat resistance and strength. An exception to this requirement is those seams located near cantilevers or overhangs where the presence of a reinforcement strip would compromise the substructure support strength. In this case, the seam must be reinforced in those sections between the support strips.

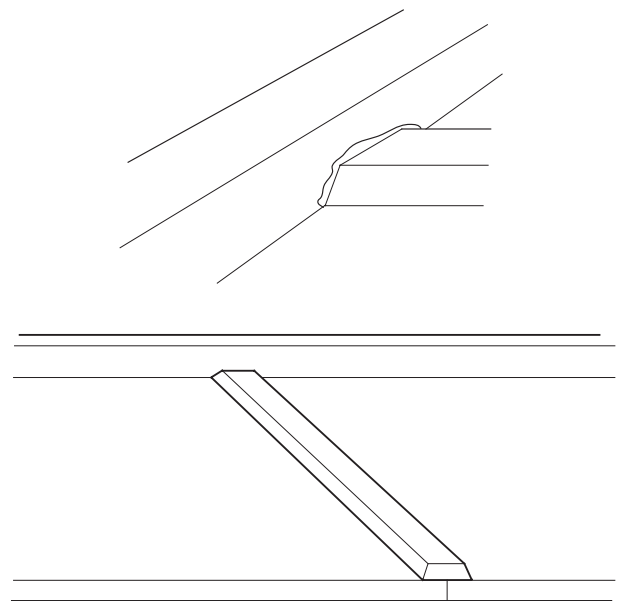

# EVERFORM® SOLID SURFACE FABRICATION GUIDE



## SEAM PREPARATION

### FIELD SEAMS

#### 1. Clamp and mirror image rout seam using a seam routing fixture.

- Use a ½ in. (12.5mm) wide, 2 flute straight carbide cutter with a ½ in. (12.5mm) shank.
- Gap about ⅜ in. (9mm) or less.
- Router must be 1½ HP or larger with ½ in. (12.5mm) collet.

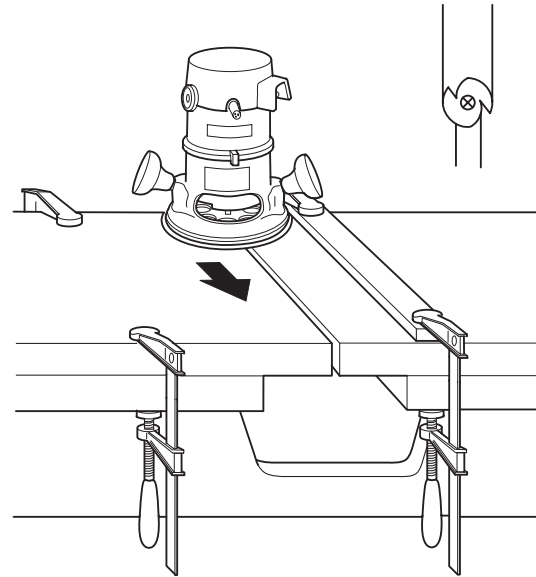

#### 2. After routing, check seam for tight fit by butting together.

- Re-rout if necessary.

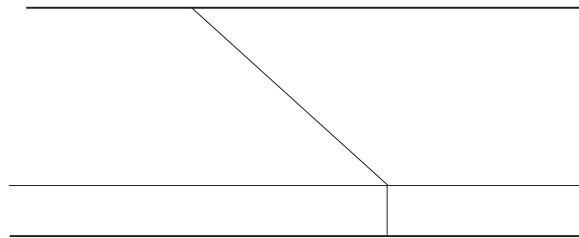

#### 3. Clean with denatured alcohol and a clean white rag.

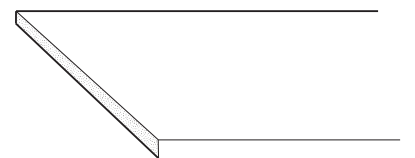
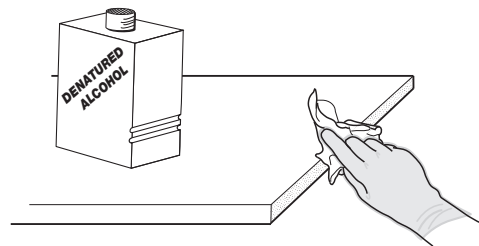

## SEAM PREPARATION

## FIELD SEAMS

#### 4. Prepare a seam reinforcement strip 3-4 in. (76-102mm) wide with a 45° chamfer on each side.

- Mill down one half of strip .010-.015 in. (.2-.3mm) on a router table to allow for excess adhesive.
- Using the seaming adhesive, bond unmilled side to bottom edge of one of the countertop sections after sanding and cleaning with an alcohol dampened white cloth.

**Note:** The seam reinforcement strip should be bonded to the section or sections that are to be installed first to facilitate installation.

- Apply clamps and remove excess adhesive from overhang with a sharp chisel before adhesive sets.

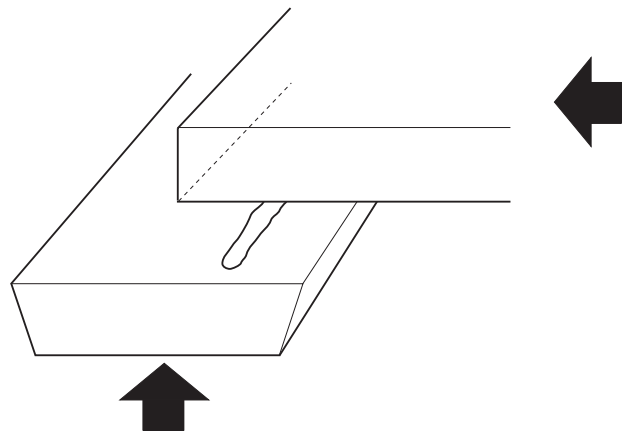

#### 5. When on site, position countertop section having reinforcing strip first.

- Next, position adjoining side and check for fit.
- Level and shim as necessary.
- Sand top surface near the seam line with 120-grit sandpaper to provide a bonding area for hot melt adhered wood blocks.

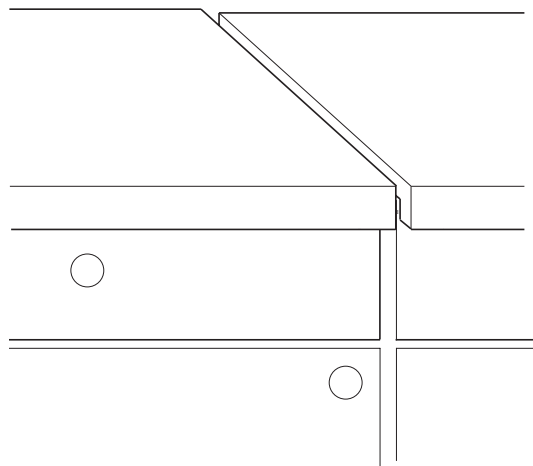

#### 6. Separate two sections and clean joint area with alcohol and clean white rag.

- Adhere wood blocks with hot melt adhesive.
- Blocks should be approximately 2 ½ in. x 4 in. x ¾ in. (6cm x 10cm x 20mm)

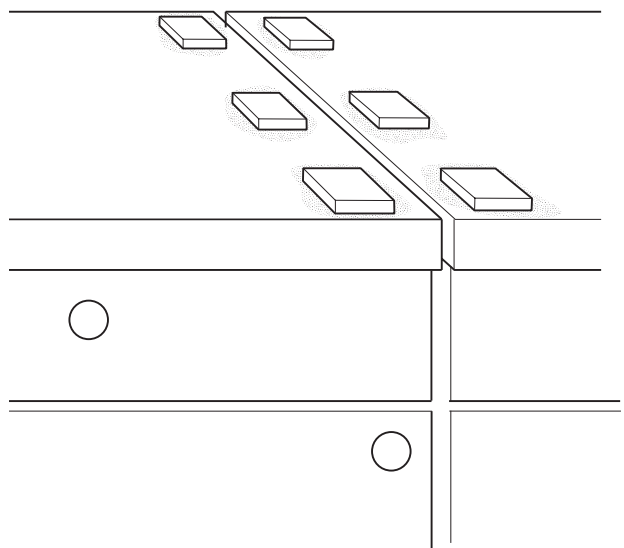



# EVERFORM® SOLID SURFACE FABRICATION GUIDE



## SEAM PREPARATION

### FIELD SEAMS

#### 7. Apply seaming adhesive to reinforcement strip and press sections together.

- Leave 1/8 in. (3mm) gap.

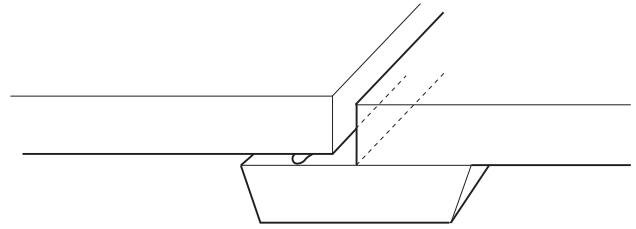

#### 8. Fill gap with seaming adhesive of appropriate color.

- Protect cabinet interiors, fronts and floor from excess adhesive with clear packaging tape, aluminum foil or wax paper.

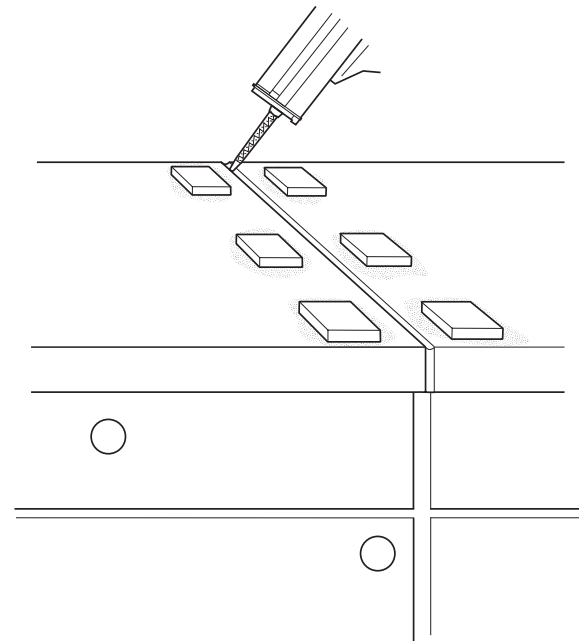

#### 9. Push joint together and apply clamping pressure.

Excess adhesive will squeeze out. Do not remove excess adhesive.

Do not over tighten.

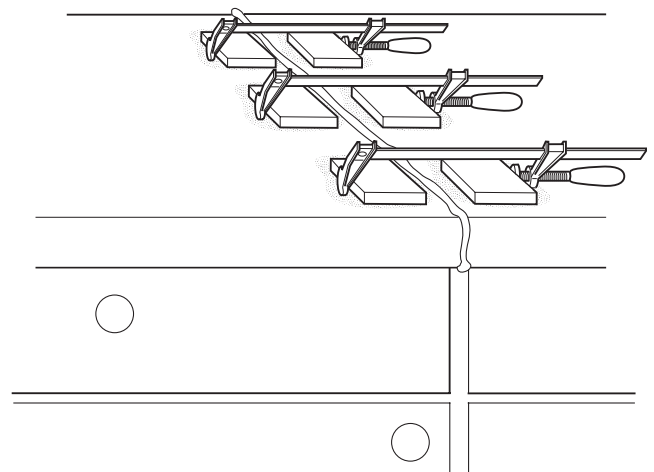

# EVERFORM® SOLID SURFACE FABRICATION GUIDE



## SEAM PREPARATION FIELD SEAMS

### 10. After adhesive sets (about 45 mins.), remove clamps and wood blocks.

- Remove wood blocks by flooding with alcohol and then prying off with a wood chisel.
- Protect the surface with laminate sample under chisel.
- Any residual hot melt adhesive can be removed from surface with a sharp chisel having rounded corners to avoid gouging.

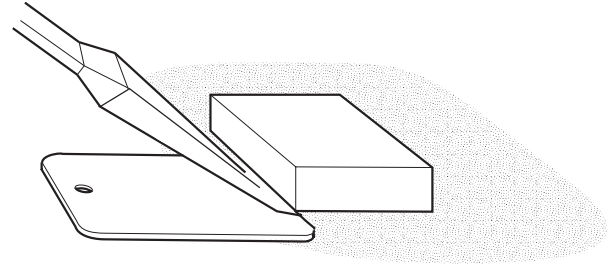

### 11. Remove adhesive bead using a router with a ski base and a flat bottom cutter set just above surface.

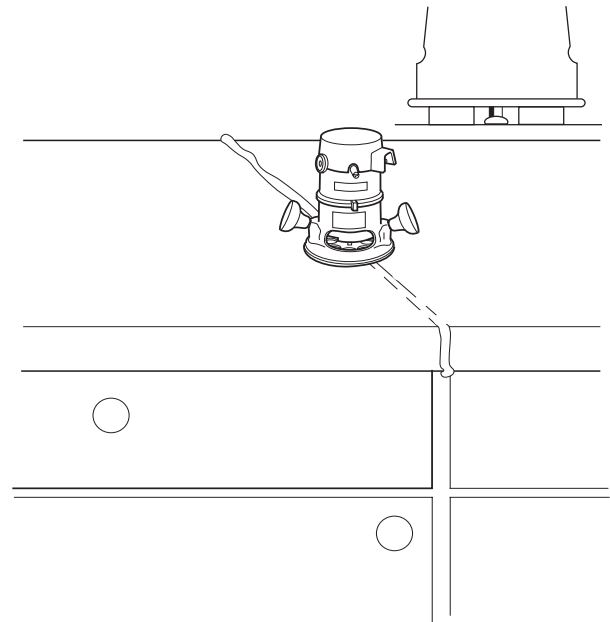

### 12. Use a stiff base random-orbital sander with 100 to 120-grit sandpaper to remove remaining adhesive and to level out seam.

- Final finishing is normally done after final fabrication steps are completed.

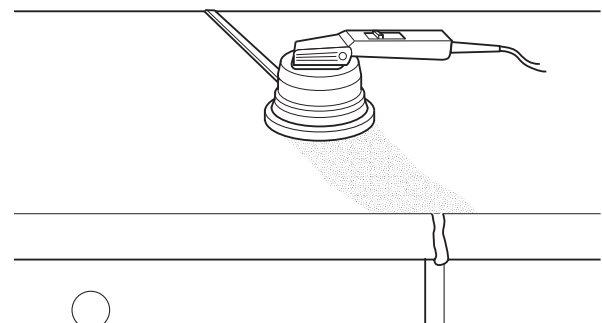

# EVERFORM® SOLID SURFACE FABRICATION GUIDE



## BASIC EDGE ASSEMBLIES SURFACE-TO-SURFACE INSIDE CORNER DETAIL

### Surface-to-Surface (see page 21 for assembly instructions)

- Strongest.
- Multiple profile selections.
- Most versatile for inside and outside corner fabrication.
- Least machining before assembly.
- Allows incorporation of other colors, or patterns.

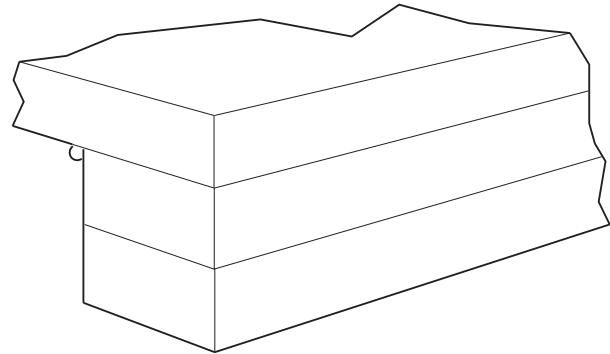

### Double Edge-on-Edge (see page 22 for assembly instructions)

- Multiple profile selections.
- Complicates inside and outside corner fabrication.
- Requires extra machining step for tight joint.
- Does not allow incorporation of another color or pattern in edge build-up.

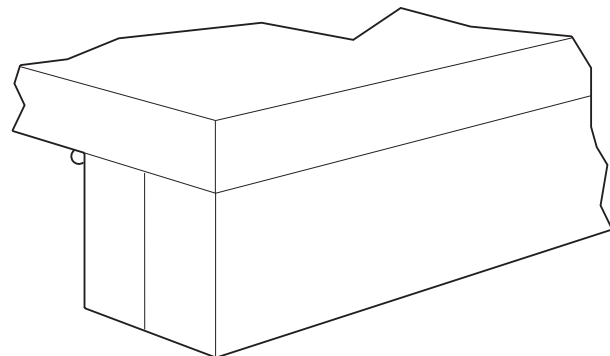

### Single Edge-on-Edge (see page 24 for assembly instructions)

- Recommended only for overhanging edges having minimal clearance.
- Limited profile selection.
- Least impact resistance.
- Weakest inside corner strength.
- Requires extra machining step for tight joint.
- Does not allow incorporation of another color or pattern in edge build-up.

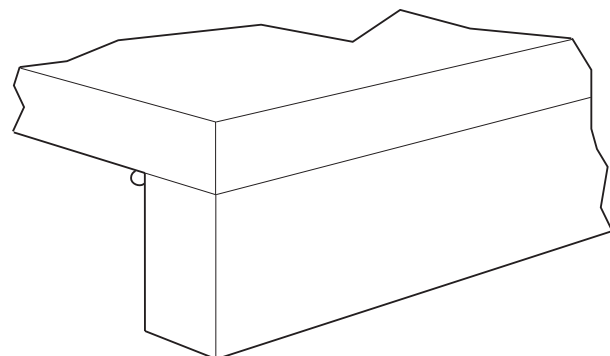

# EVERFORM® SOLID SURFACE FABRICATION GUIDE



## BASIC EDGE ASSEMBLIES

### SURFACE-TO-SURFACE INSIDE CORNER DETAIL CONTINUED

#### NOTE: TO ACHIEVE THE BEST POSSIBLE EDGE APPEARANCE:

- Sand the back side of the countertop deck (in the drop edge area) and the face and back of each edge strip with 120 grit (100 micron) sandpaper using a random orbital sander.
- Sand until the white lines have been removed from the back and until the face has been roughed up enough to ensure proper bonding.
- Always glue the face of the material to the back of the next piece in the drop edge assembly.

#### 1. Cut a rectangular corner block of sufficient size to allow one end to overlap deck seam by 1 in. (25mm) or more.

- Cut radius with a router, saber or band saw.
- Cut 1/8 in. (3mm) or more away from final trim line if using saber or band saw.

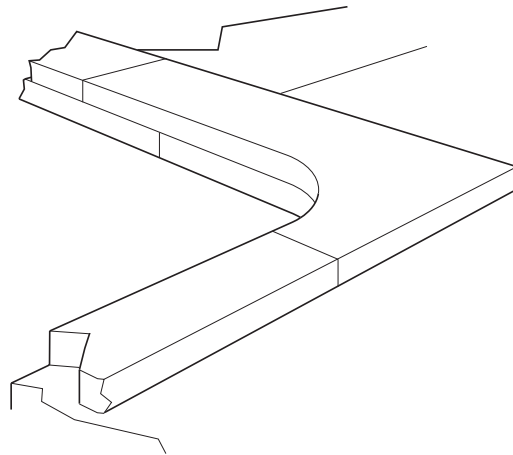

#### 2. Sand all surfaces to be bonded with 120-grit sandpaper.

- Dry fit corner pieces and edge strips.
- Sand all butting joints for a tight fit on a disk/edge sander equipped with 80-grit paper.
- Clamp temporarily into place.

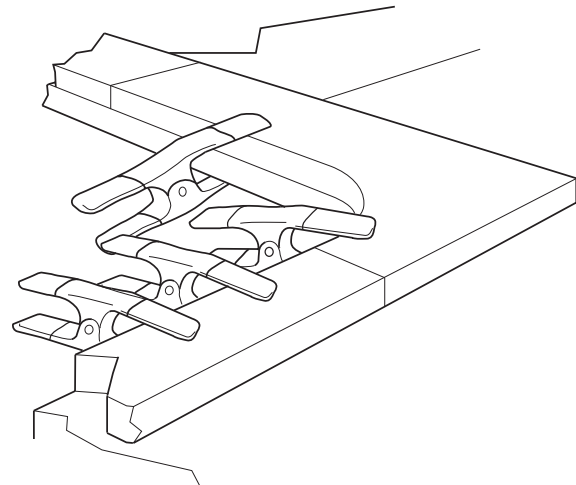

#### 3. After all edges are fitted, adhere hot melt glue blocks in strategic locations.

- Remove pieces and clean with alcohol and a clean white cloth.
- Removal of wood blocks is easier if they are glued at an angle.

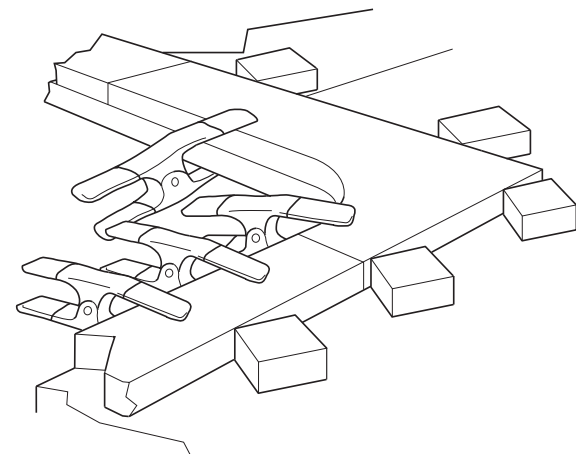

# EVERFORM® SOLID SURFACE FABRICATION GUIDE



## BASIC EDGE ASSEMBLIES

### SURFACE-TO-SURFACE INSIDE CORNER DETAIL CONTINUED

#### 4. Apply seaming adhesive to corner piece.

- Use beads of seaming adhesive in crossing patterns at corners and at ends to assure sufficient adhesive coverage.
- Assemble within 2 minutes or less after applying adhesive bead.
- Apply small bead of adhesive at all butt joints. Do not spread.

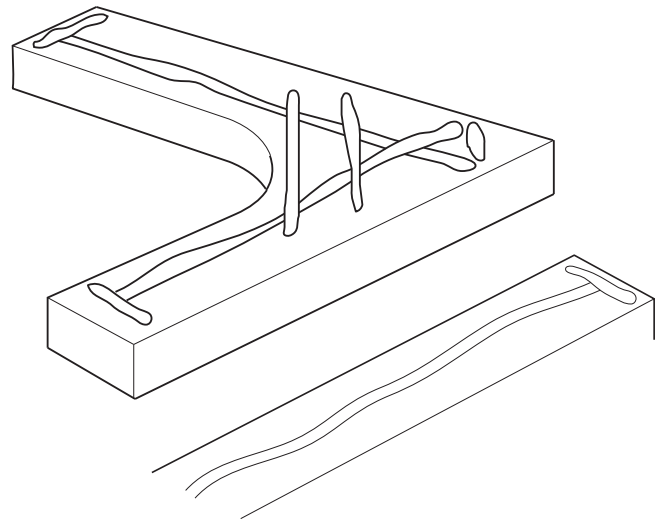

#### 5. Apply adhesive and quickly re-position each piece.

- Apply spring clamps every 2-3 in. (50-76mm) before adhesive gels.
- See typical working times for adhesive in adhesive section.
- Make sure a continuous squeeze-out is obtained.
- Allow adhesive to set (about 45 minutes).
- Remove clamps and sand edge butt seams flush before fitting next layer.

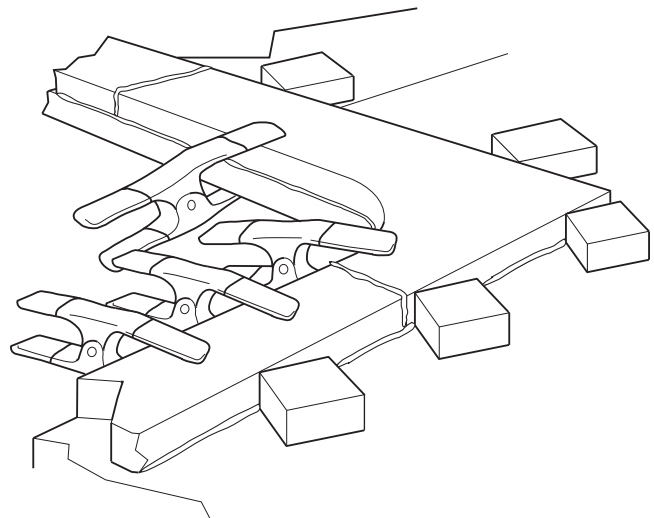

#### 6. Remove previously adhered wood blocks.

- Dry fit next edge layer.
- Adhere new hot melt wood blocks, having a notched out section to allow contact with only the new edge layer.
- Glue and clamp as for first layer.

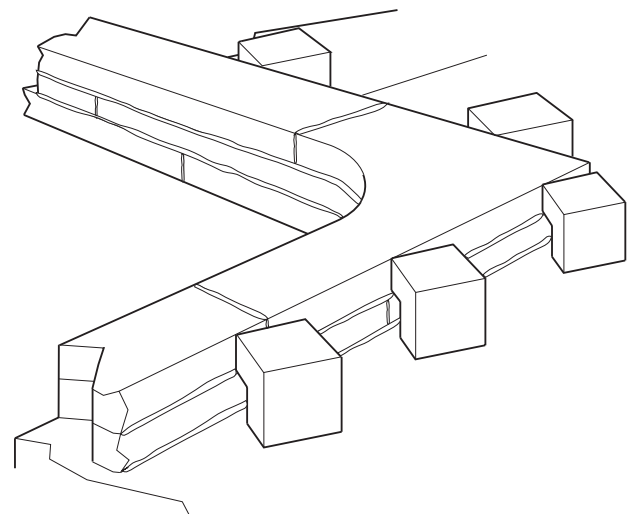

# EVERFORM® SOLID SURFACE FABRICATION GUIDE



## BASIC EDGE ASSEMBLIES

### DOUBLE EDGE-ON-EDGE INSIDE CORNER DETAIL

#### 1. Pre-cut, sand and clean corner pieces with an alcohol dampened, clean, white cloth.

- Pre-assemble corner sections and bond together with seaming adhesive.
- Clamp and allow adhesive to cure.

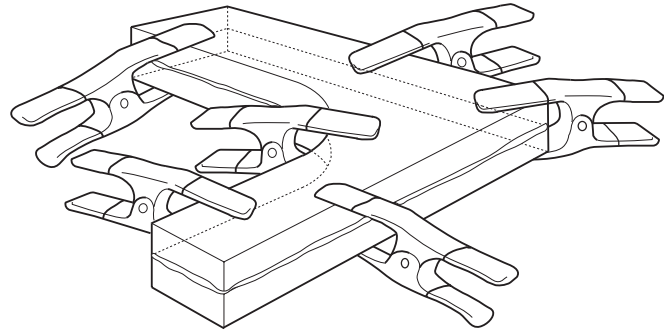

#### 2. Pre-assemble edge pieces by bonding two strips together.

- Clamp and allow adhesive to set (about 45 minutes).
- Remove excess adhesive from double edgestrips with a router table and feather boards.
- Finish to desired size.

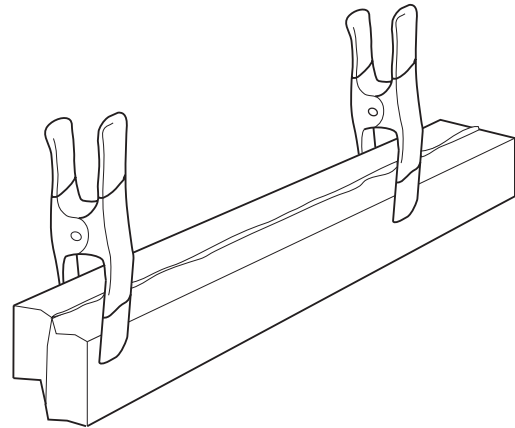

#### 3. Square up ends and dry fit corner piece. Temporarily clamp in place.

- Square up ends and dry fit doubled edge strips.
- Temporarily clamp in place.

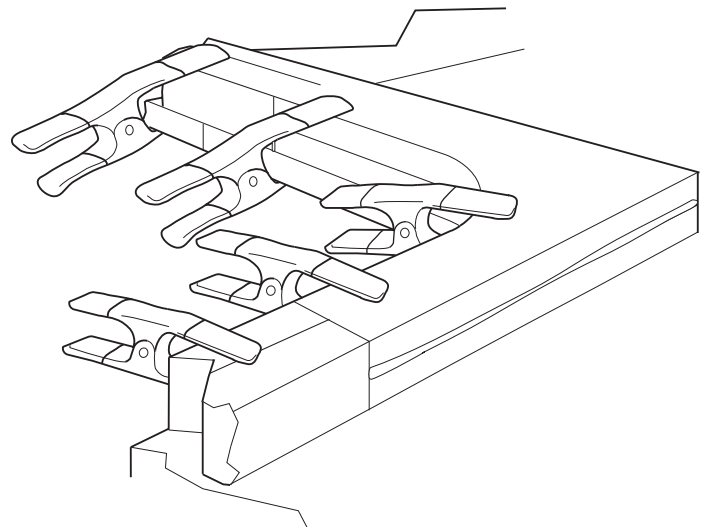

# EVERFORM® SOLID SURFACE FABRICATION GUIDE



## BASIC EDGE ASSEMBLIES

### DOUBLE EDGE-ON-EDGE INSIDE CORNER DETAIL

#### 4. Bond hot melt glue wood blocks in strategic locations after all edge pieces are fitted.

- Wipe with a clean white cloth and alcohol.
- Removal is easier if blocks are glued at angles.

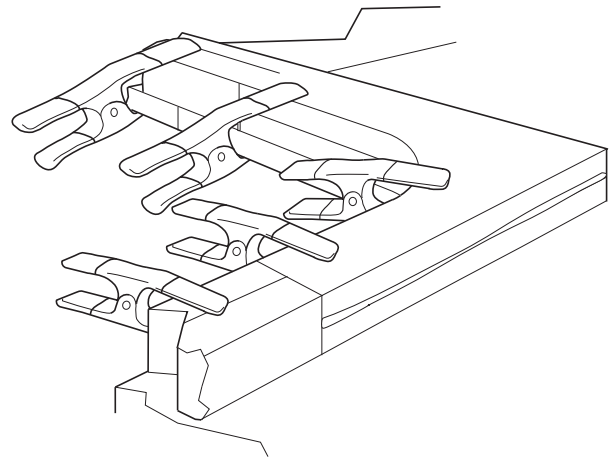

#### 5. Re-assemble corner piece and edge strips using Everform® Solid Surface seaming adhesive and apply clamps.

- Clamp placement should be 3-4 in. (76-102mm) apart.

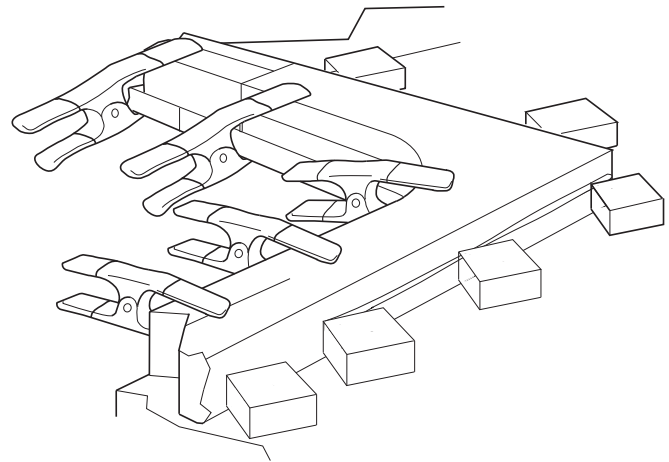

# EVERFORM® SOLID SURFACE FABRICATION GUIDE



## BASIC EDGE ASSEMBLIES SINGLE EDGE-ON-EDGE INSIDE CORNER DETAIL

### 1. Pre-cut, sand and clean corner pieces with an alcohol dampened cloth.

- Pre-assemble corner sections and bond together with seaming adhesive.
- Clamp and allow adhesive to cure.
- Square ends after adhesive sets.

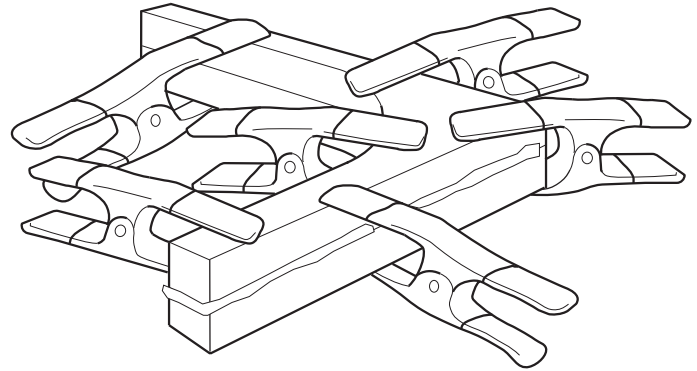

### 2. Pre-rout, sand and clean edge strips with an alcohol dampened cloth.

- Dry fit corner piece and edges.
- Temporarily clamp in place.
- Apply hot melt glue blocks in strategic locations after all pieces are fitted.
- Removal is easier if blocks are glued at angles.

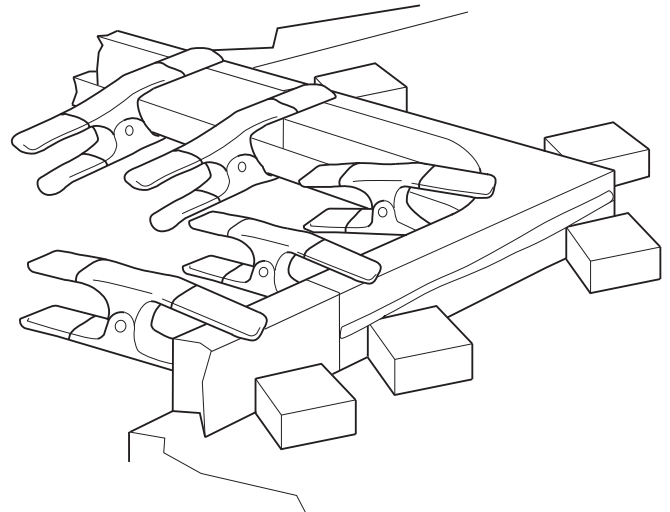

### 3. Re-assemble using seaming adhesive.

Apply spring clamps 3-4 in. (76-102mm) apart.

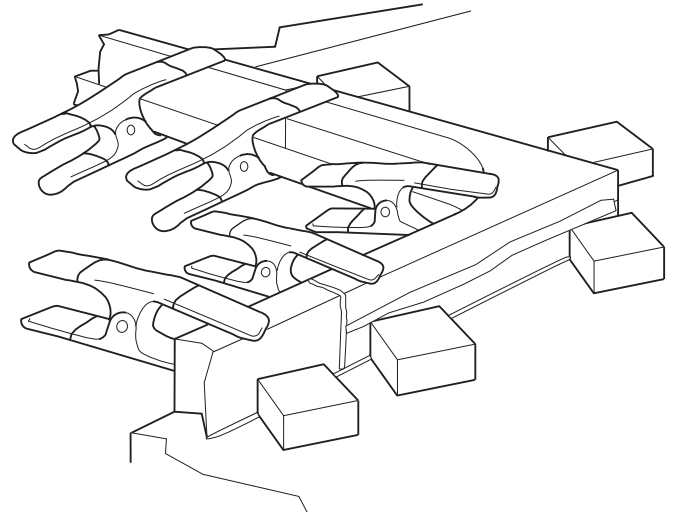





## CUSTOM PROFILES

**SQUARE**



**BULLNOSE**



**EASED**

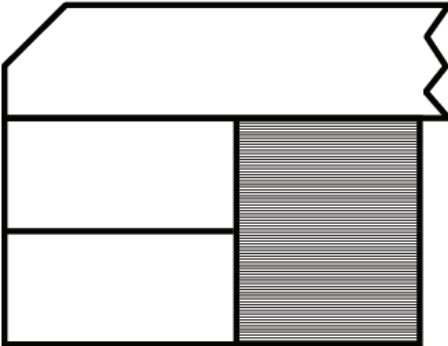

**BEVEL**



COUNTERTOPS

# EVERFORM® SOLID SURFACE FABRICATION GUIDE



## UNDERMOUNTED SINKS

### 1. Flip top over (bottom side up).

- Determine location for sink placement.
- Scratch in center lines with an awl.

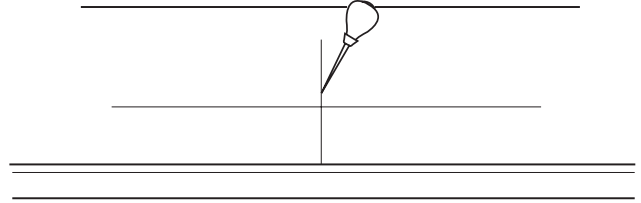

### 2. Center sink on top using center alignment marks on sink.

- Scratch outside perimeter of sink onto backside of top.

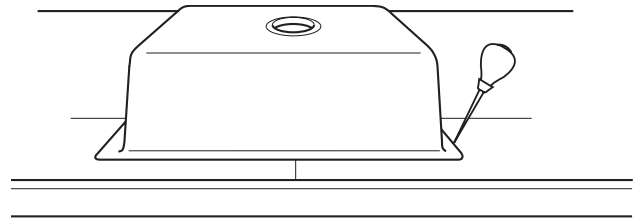

### 3. Sand bonding area on sheet with 60-grit sandpaper.

- Plunge rout a 1-2 in. (25-50mm) hole.
  - Note:** If clamping through the drains, the ventilation hole(s) should be routed directly under the drain opening(s). Make holes large enough to allow clamp access.
- Clean bond area with a denatured alcohol dampened clean, white cloth.

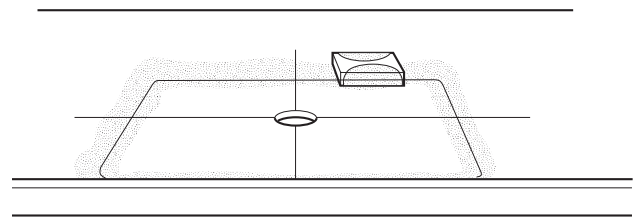

### 4. Install hot melt glue blocks to keep sink from moving off-center when bonding.

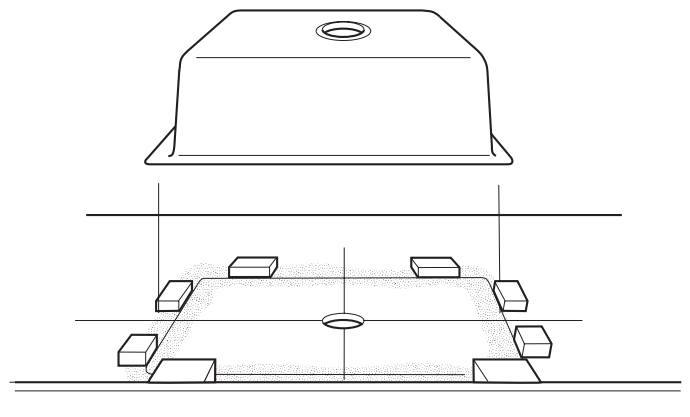

# EVERFORM® SOLID SURFACE FABRICATION GUIDE



## UNDERMOUNTED SINKS

### 5. Sand top edge of sink with 60-grit sandpaper.

- Do not round over inside perimeter.

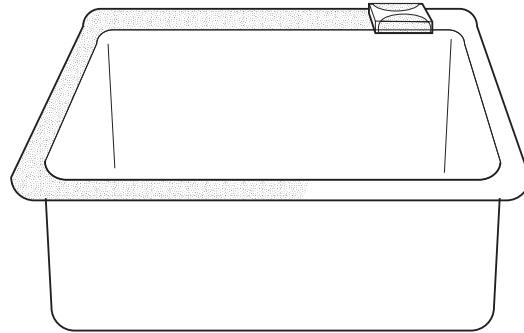

### 6. Clean flange with denatured alcohol and a clean white rag.

- Allow to dry.

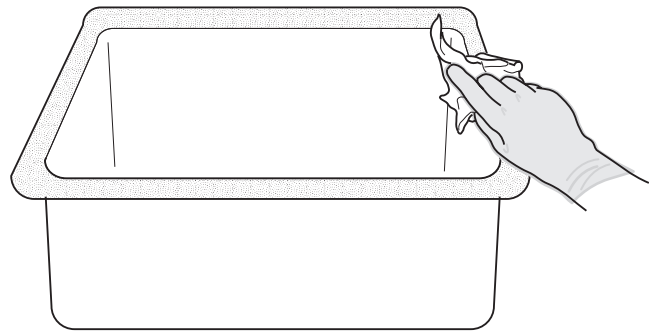

### 7. Apply a ¼ in. (6mm) or larger bead of seaming adhesive to flange.

- Do not spread.

**Note:** Use adhesive color that matches the sink color.

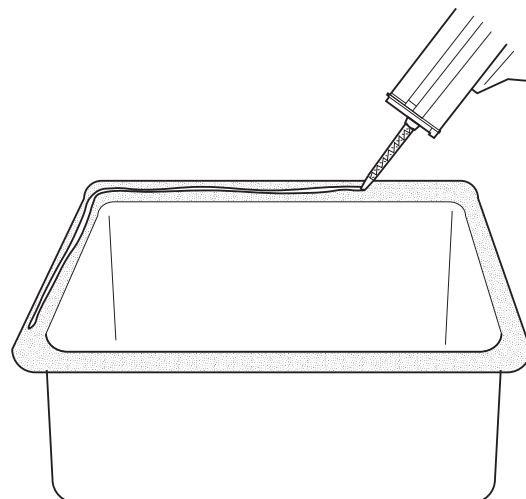

# EVERFORM® SOLID SURFACE FABRICATION GUIDE



## UNDERMOUNTED SINKS

### 8. Invert sink and press into place with slight movement to transfer adhesive.

- Sink must be set in place within 2 minutes after adhesive is applied.

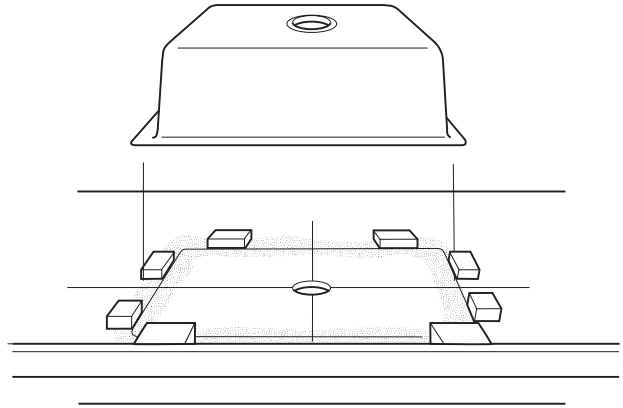

### 9. If clamping with a bar or pipe clamp through the drain and sheet vent hole, use a wood beam to distribute pressure.

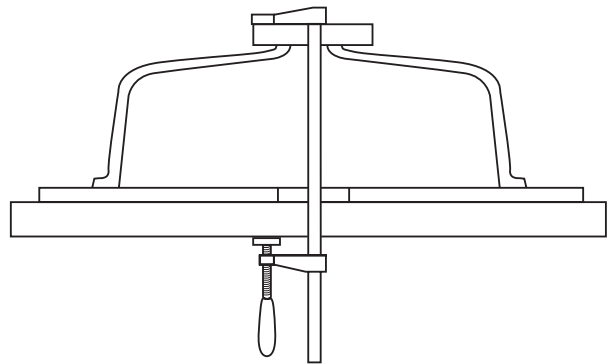

### 10. Clamp the four corners and both the front and back mid-sections of the sink with adjustable, deep throated clamps.

- Use ½ in. x 1 in. x 4-6 in. (12mm x 25mm x 102-152mm) wood strips as stand-offs for clamping.
- Allow adhesive to cure.

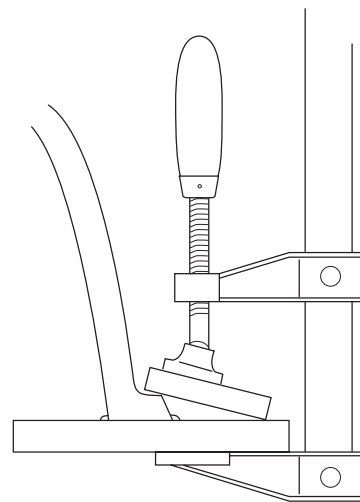

# EVERFORM® SOLID SURFACE FABRICATION GUIDE



## UNDERMOUNTED SINKS

### 11. Remove clamps and turn the countertop right side up onto a sturdy support.

- Using a Formica® Brand #KSST carbide stagger tooth cutter, cut out sink opening.
- Catch sink cut-out piece to avoid damage.

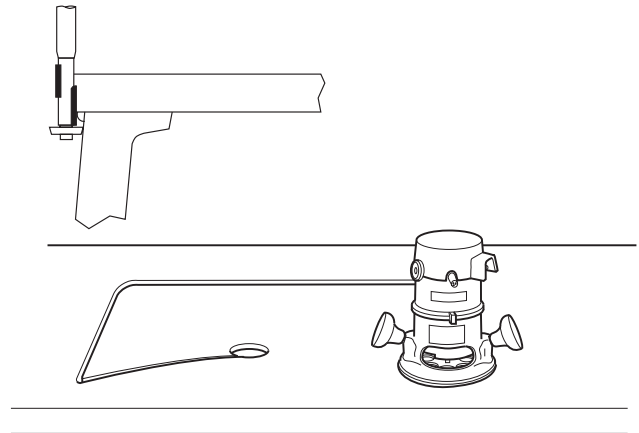

### 12. Use a Formica® Brand #KSRO carbide round-over cutter to shape sink lip.

- Sand out chatter and smooth lip with 120-grit and finer abrasives.

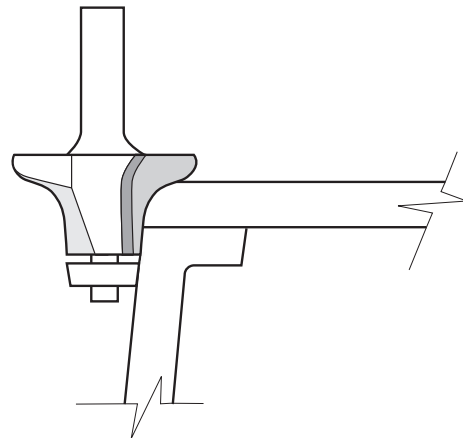

# EVERFORM® SOLID SURFACE FABRICATION GUIDE



## INSTALLING COOKTOPS

**NOTE:** The maximum operating temperature of the Everform® Solid Surface (in the cutout area) should not exceed 175°F (79°C). If higher temperatures are experienced, cracking can occur and other design alternatives are required.

### 1. Using appropriate template and template guide, cut out opening with a single flute ½ in. (12.5mm) cutter.

- Minimum inside corner radius for a heat producing drop-in unit is ½ in. (12.5mm).
- Make sure all seams are at least 3 in. (76mm) away from cooktop opening.

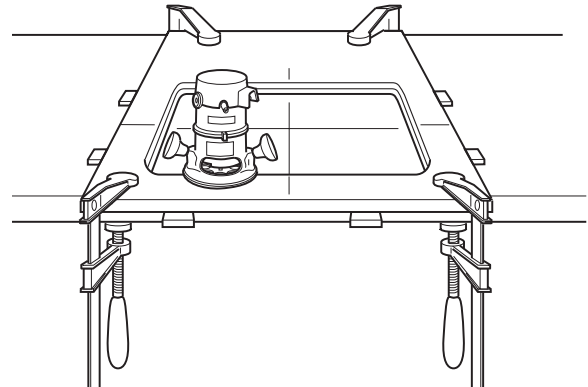

### 2. Flip countertop over.

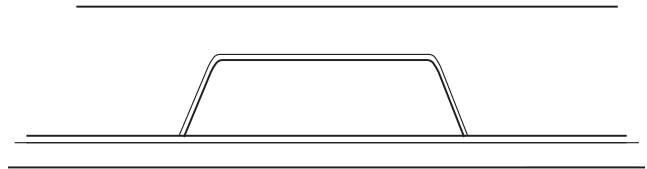

### 3. Cut out four 3 in. x 3 in. (76mm x 76mm) or larger blocks of Everform® Solid Surface.

- Cut 45° angle chamfers on all non-abutting edges.

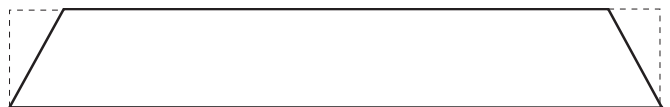

## INSTALLING COOKTOPS

### 4. Bond a beveled block in each of the four corners with seaming adhesive.

- Butt front corner blocks into the drop edge and bond with seaming adhesive.
- Clamp and allow adhesive to set.
- Cut out excess with a ball bearing guided carbide router bit.
- Slightly round over sharp edges and sand smooth—remove any chips, etc.
- Minimum inside radius should be  $\frac{1}{2}$  in. (12.5mm) or larger.

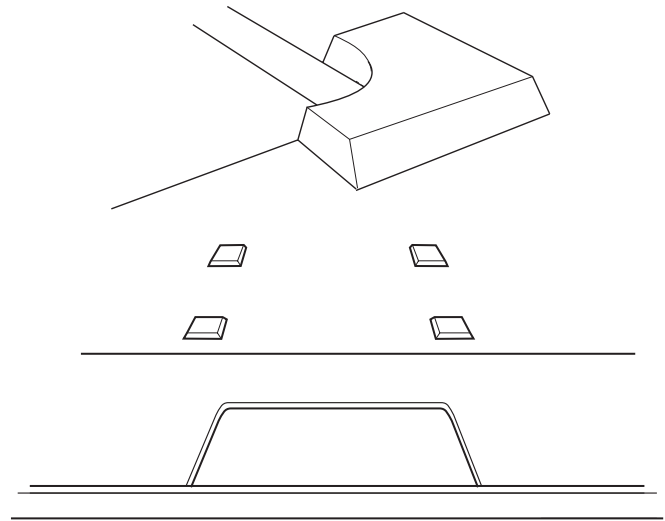

### 5. Apply two layers of heat conductive aluminum tape\* as illustrated.

- Tape is bent back and separated on underside to provide better heat dissipation.
- Install cooktop into countertop.
- Cooktop flange must rest on aluminum tape.
- Gap between cooktop flange and cutout edge must be at least  $\frac{1}{8}$  in. (3mm) all around.

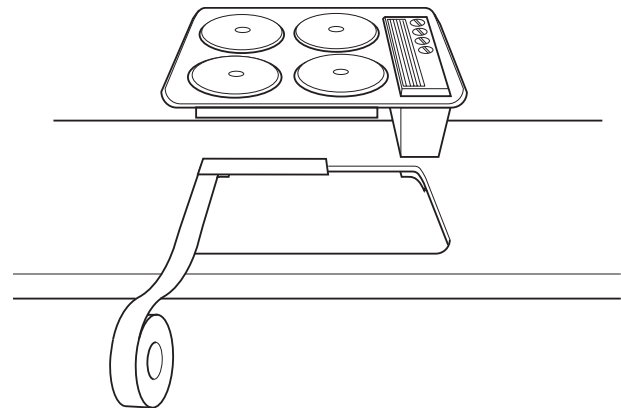

### 6. Cut away excess conductive aluminum tape with a razor knife.

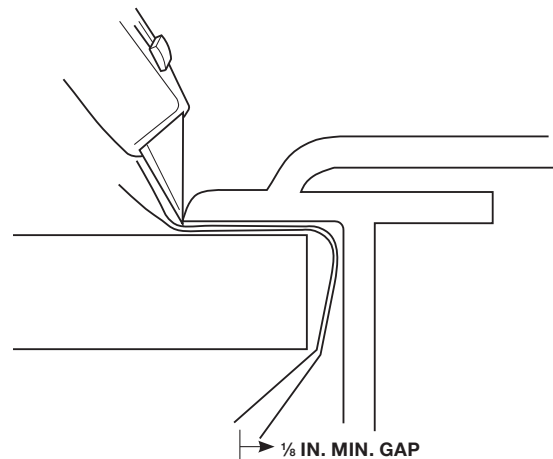

\* Heat conductive metal tape such as Scotch® brand Aluminum Foil Tape #425 or #427.

## COUNTERTOP SUPPORT

Countertops fabricated from Everform® Solid Surface must be properly supported by a web or grid support system. This support configuration provides the necessary support while permitting the surface to dissipate heat effectively. Solid wood substrates such as plywood, MDF or particleboard should only be used in applications where the top will not be subject to heat buildup from appliances, hot objects, etc.

The grid or web substructure should be fabricated from 2½-3 in. wide by ¾-1 in. thick plywood, kiln-dried lumber, MDF or ¾-1 in. tubular steel with a ⅛ in. minimum wall thickness. Do not use particleboard strips. This material lacks sufficient structural strength and can swell and heave if exposed to water. Do not use solid surfacing material for support due to its flexural properties.

Do not use a full wood underlayment as a support for horizontal sheets.

Dust covers in cabinets can act like underlayment or a solid substrate. Solid topped cabinets, corner cabinets and lazy-susan cabinets must be ventilated to prevent air from being trapped. The top of the cabinet must be cut out as much as possible without hurting the integrity of the cabinet. This will allow heat to dissipate into the cabinet.

### SUPPORT CRITERIA

- For tops fabricated from ½ in. thick material, provide support every 18 in. or less. This is typically obtained by running a 1 in. thick wood or tubular steel support strip along the back and down the middle and the front edge (if necessary).
- For tops fabricated from ¾ in. thick material, provide support every 24 in. or less. This is typically obtained by running a ¾ in. thick wood or tubular steel support strip along the back and the front edge (if necessary).
- Provide perimeter support within 3 in. of the flanges of undermounted Everform® Solid Surface kitchen sinks.
- For tops fabricated from ½ in. thick material, all cantilevers or overhangs in excess of 6 in. require structural support.
- For tops fabricated from ¾ in. thick material, all cantilevers or overhangs in excess of 12 in. require structural support.
- Wood support strips must be held back ⅛ in. from drop edges of all returns to avoid binding due to frame expansion or top contraction.
- Support grid or cabinets must be set level and even within ⅛ in. maximum variance in 10 feet.
- Adhere support grid only with 100% silicone adhesive. Do not use rigid adhesive such as construction adhesive.



# EVERFORM® SOLID SURFACE FABRICATION GUIDE



## COUNTERTOP SUPPORT

### 1. If using a plywood or kiln-dried lumber support grid:

- Adhere lumber, plywood or MDF to bottom of finished top with dabs of silicone at 12 in. (305mm) intervals. These are typically adhered along the front, back and middle as illustrated.
- Clamp or hold in place with hot melt adhesive until silicone cures.
- Leave 1/8 in. (3mm) gaps at junctions, etc., to allow for wood expansion.

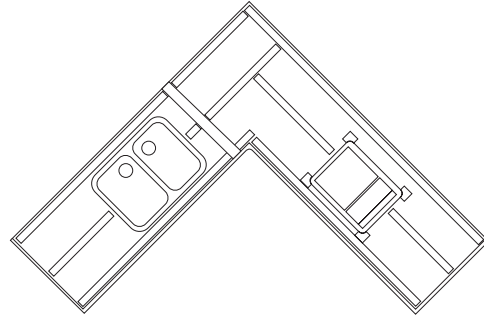

### 2. Set top in place on pre-leveled cabinets with dabs of silicone every 12-18 in. (305-457mm) on front and back, etc.

- Cabinets should be mechanically fastened together and to the wall and/or the floor.

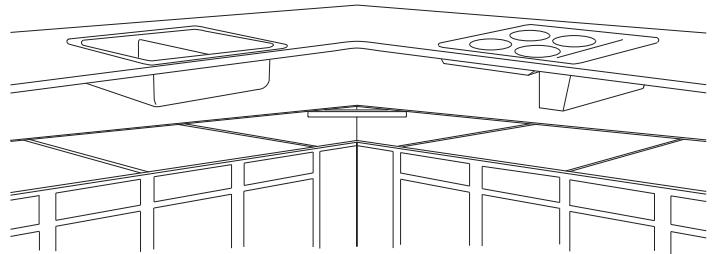

### 1. If using a tubular steel support:

- Tubular steel can be mechanically fastened to the cabinets in the desired grid configuration with countersunk flathead screws. Shim and level as necessary.

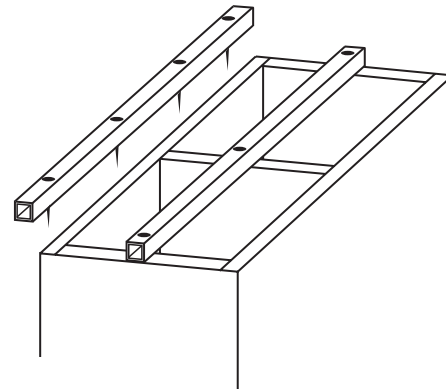

### 2. Apply dabs of silicone at 12-18 in. (305-457mm) intervals on the tubular steel and install countertop.

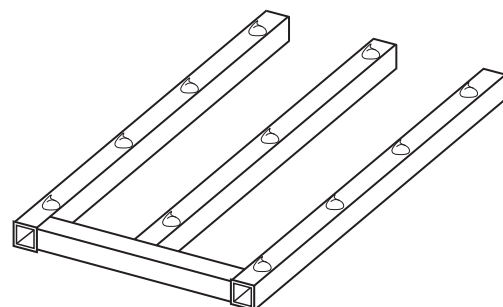

## OVERHANG SUPPORT

For countertops, etc., fabricated from ½ in. thick Everform® Solid Surface, the maximum unsupported overhang or cantilever is 6 in. (152mm). For tops fabricated from ¾ in. thick material, the maximum unsupported overhang or cantilever is 12 in. (305mm). All overhangs or cantilevers in excess of these limits will require sufficient structural support. The following are acceptable methods for supporting cantilevers or overhangs:

- Braces or brackets
- Tubular steel
- Hardwood

**NOTE:** Seams in extra wide islands or peninsulas must not be positioned directly over the cabinet frame member next to a cantilever or overhang section. This is a stress point. Offset seams in this area at least 3 in. (76mm) into the cabinet or out into the cantilever section. Reinforce the backside of these seams with seam reinforcement strips bonded between the support members.

# EVERFORM® SOLID SURFACE FABRICATION GUIDE



## OVERHANG SUPPORT TECHNIQUES USING SUPPORT BRACKETS

### 1. If using support brackets:

- Brackets may be constructed from metal or wood (plywood/hardwood).
- Dimension "leg" of bracket to reduce the unsupported overhang to 6 in. (152mm) or less.

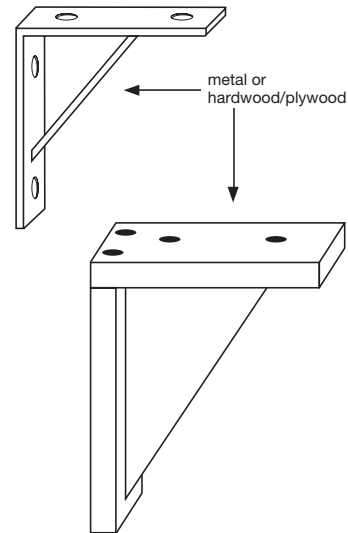

### 2. Brackets must be securely fastened to structurally sound cabinet side or back—typically ¾ in. plywood or other installed frame member.

- Space brackets 24 in. (610mm) on center maximum.

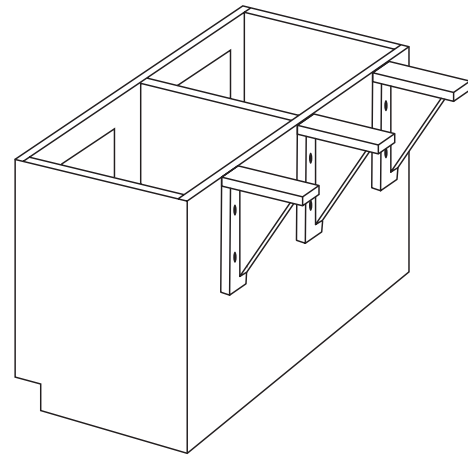

### 3. Install fabricated top over properly spaced web support that spans the ends of the support braces. Support web should be mechanically fastened to the cabinet and braces and adhered to the countertop with silicone dabs spaced at 12-18 in. (305-457mm) intervals.

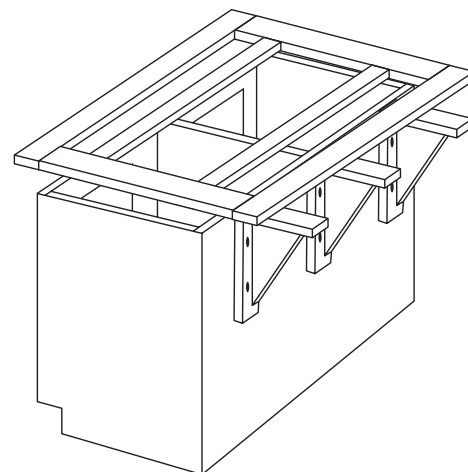

# EVERFORM® SOLID SURFACE FABRICATION GUIDE



## OVERHANG SUPPORT TECHNIQUES USING TUBULAR STEEL

### 1. If using tubular steel:

- Use  $\frac{3}{4}$ -1 in. (19-25mm) square tubular steel with  $\frac{1}{8}$  in. (13mm) minimum wall thickness.

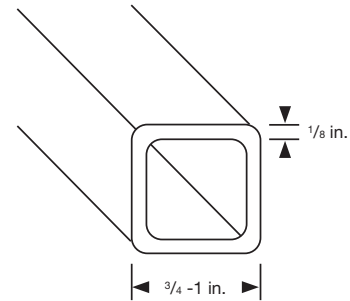

### 2. Space at 12 in. (305mm) maximum, on center.

- Fasten to cabinets with countersunk screws.

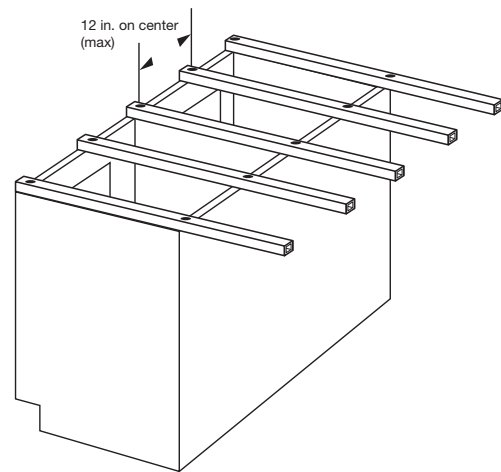

**NOTE:** Maximum overhang with  $\frac{3}{4}$  in. (19mm) tubular steel is 12 in. (305mm) and 20 in. (508mm) with 1 in. (25mm) tubular steel. Overhangs in excess of these limits will require the use of support brackets or braces.

# EVERFORM® SOLID SURFACE FABRICATION GUIDE



## OVERHANG SUPPORT TECHNIQUES USING HARDWOOD SUPPORT

### 1. If using hardwood support:

- Preferred wood species are hard or soft maple, red or white oak and ash.
- Select components that are straight and void of knots.

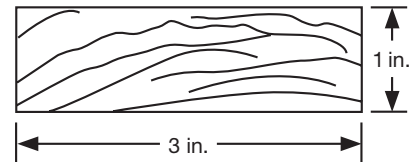

### 2. Construct support web with struts placed on 12 in. (305mm) maximum centers. Joints may be doweled and glued or assembled with screws.

- Use a continuous header to join struts.
- Fasten support grid to cabinet frame with countersunk screws.
- Attach countertop to support frame with silicone applied at 12-18 in. (305-457mm) intervals.

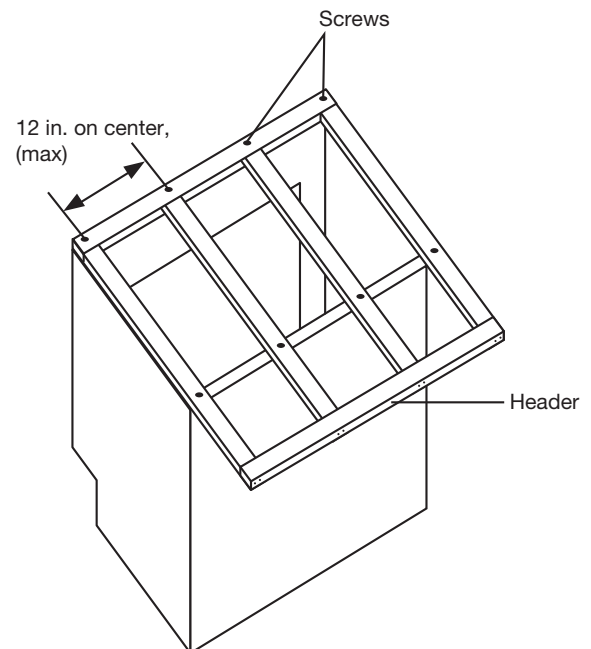

Note: Maximum overhang with a hardwood support grid is 16 in. (406mm). Overhangs in excess of 16 in. (406mm) will require the use of support brackets or braces.

# EVERFORM® SOLID SURFACE FABRICATION GUIDE



## OVERHANG SUPPORT FOR COUNTERTOPS WITH CUTOUTS

**1. Countertops that have a cantilever opposite of a cutout for a drop-in sink or drop-in range require special attention to assure proper support for both drop-in unit and the cantilever.**

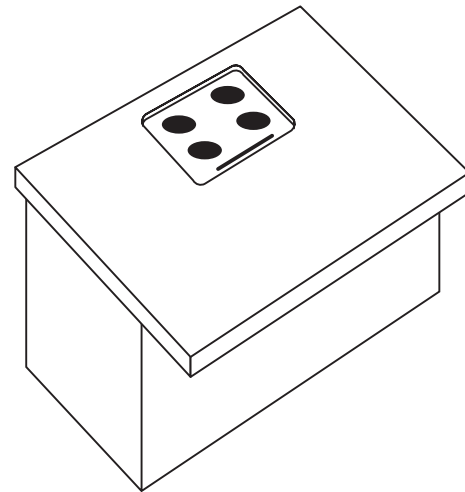

**2. Construct support grid from 1 in. x 3 in. (25mm x 76mm) hardwood with headers as illustrated. Fasten joints with dowels and glue or screws.**

- Attach support grid to cabinet frame with countersunk screws.

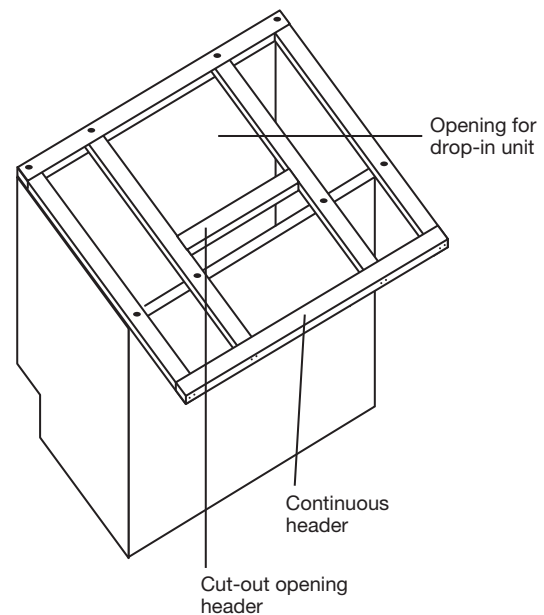

# EVERFORM® SOLID SURFACE FABRICATION GUIDE



## SQUARE BACKSPLASHES WITH FLEXIBLE JOINTS

### 1. To install finished backsplash pieces with a flexible joint, mask off adjacent areas with masking tape to simplify clean-up.

- Prepare bond area by sanding and cleaning with alcohol.
- Apply a bead of color matched 100% silicone either to the bottom of the backsplash or to the deck.

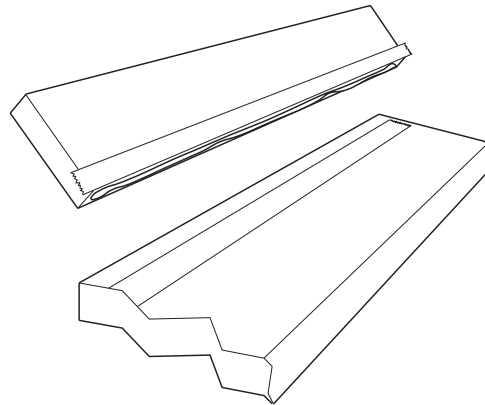

### 2. Position backsplash and hold in place by bracing or by clamping as necessary.

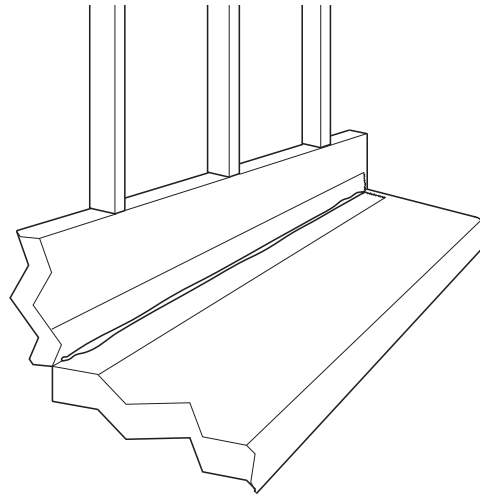

### 3. Remove excess silicone before it gels with a putty knife. Smooth out remaining bead with an alcohol dampened cloth.

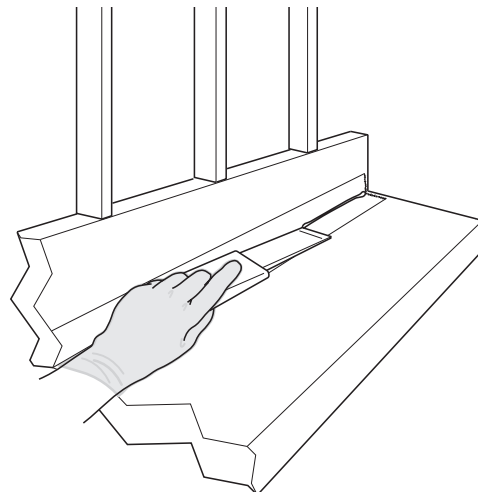

## SQUARE BACKSPLASHES WITH FLEXIBLE JOINTS

### 4. Remove tape, exposing finished seam before silicone gels.

- Let silicone cure before using.

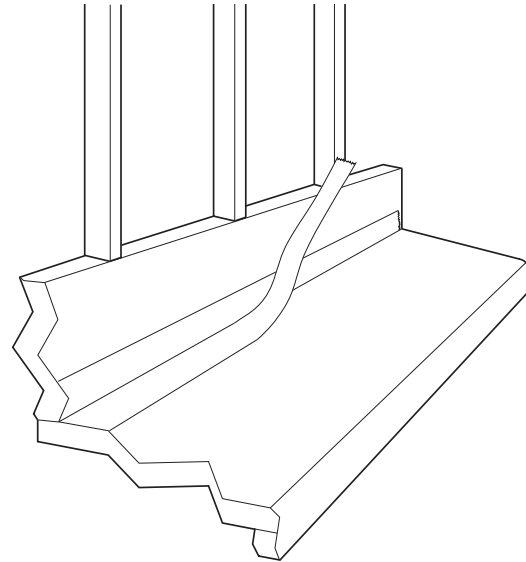



# EVERFORM® SOLID SURFACE FABRICATION GUIDE



## SQUARE BACKSPLASHES WITH RIGID JOINTS

### 1. Prepare edges by routing and sanding.

Clean with alcohol.

Mask off edges to protect surfaces from excess adhesive.

Apply a bead of seaming adhesive of the same color to the backsplash edge or to the countertop.

The minimum height for a rigid backsplash is 8 in. (203mm).

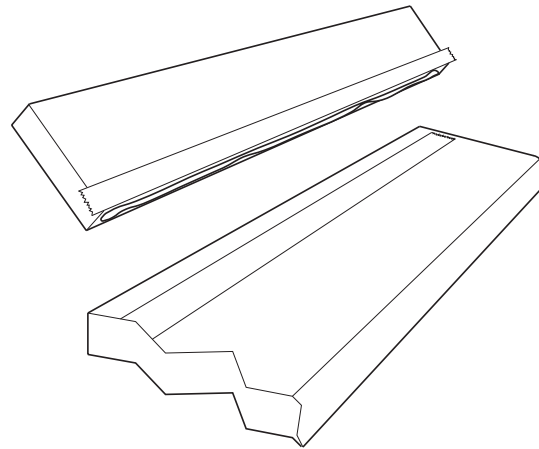

### 2. Position backsplash and hold in place by clamping or bracing as necessary.

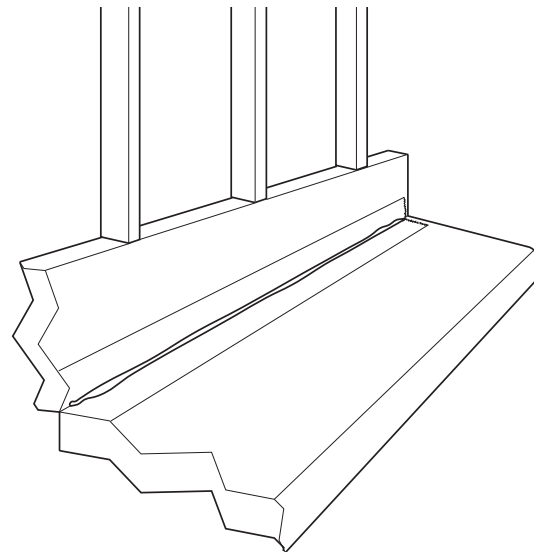

### 3. Remove excess adhesive with a putty knife before it cures.

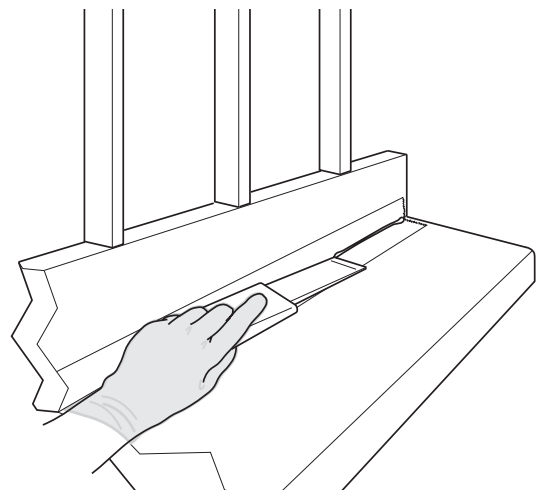

# EVERFORM® SOLID SURFACE FABRICATION GUIDE



## SQUARE BACKSPLASHES WITH RIGID JOINTS

**4. Remove protective tape, exposing joint.**

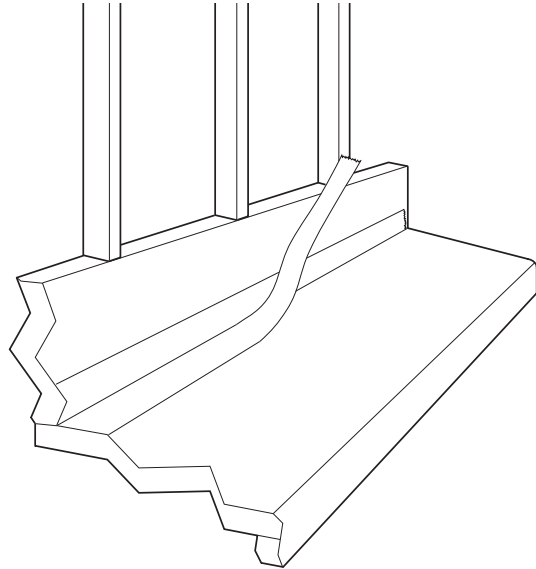

**5. Clean seam with an alcohol dampened rag before adhesive cures.**

- Do not flood joint with alcohol.

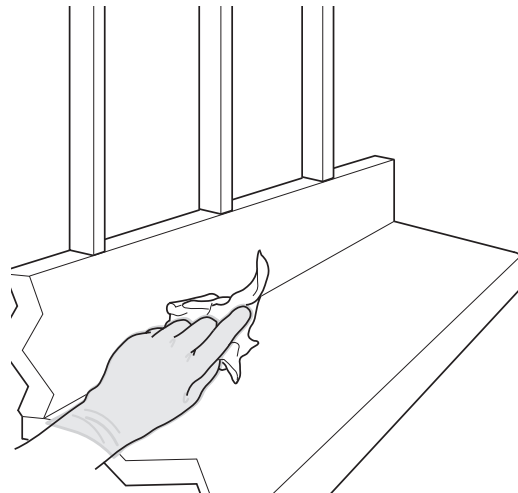

# EVERFORM® SOLID SURFACE FABRICATION GUIDE



## COVERED BACKSPASHES USING A COVING ROUTER

### USING A COVING ROUTER

**NOTE:** Due to the unique nature of the Artifacts, Mica and Ice colors, we do not recommend fabrication of a cove backspash. All seams will be extremely visible.

### 1. Prepare pieces to be bonded by routing and sanding.

- Clean with alcohol and bond back and cove pieces together using the correct seaming adhesive.

### 2. Machine a 1/8 in. (3mm) deep by 7/8 in. (22mm) wide cut into backside of countertop.

- Bond cove assembly onto countertop using the correct seaming adhesive.

### 3. Apply spring clamps and hot melt adhered blocks of wood to create forward pressure.

- Apply additional downward pressure with bar clamps.
- Check to make sure backspash section is square to the deck — adjust clamps as necessary.
- Allow adhesive to cure.

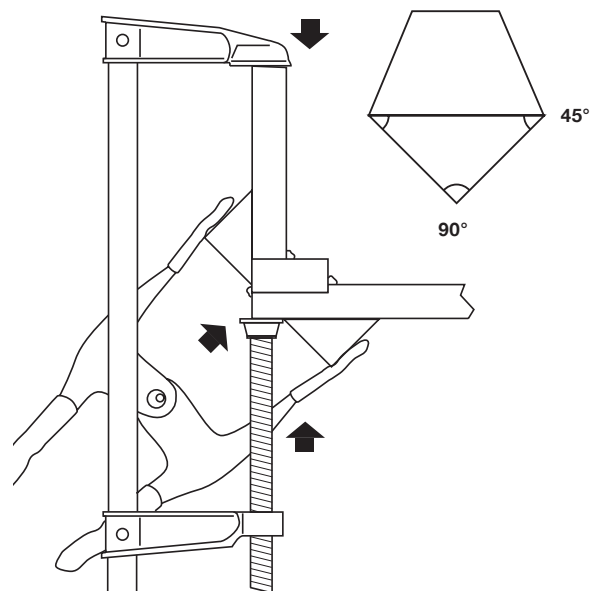
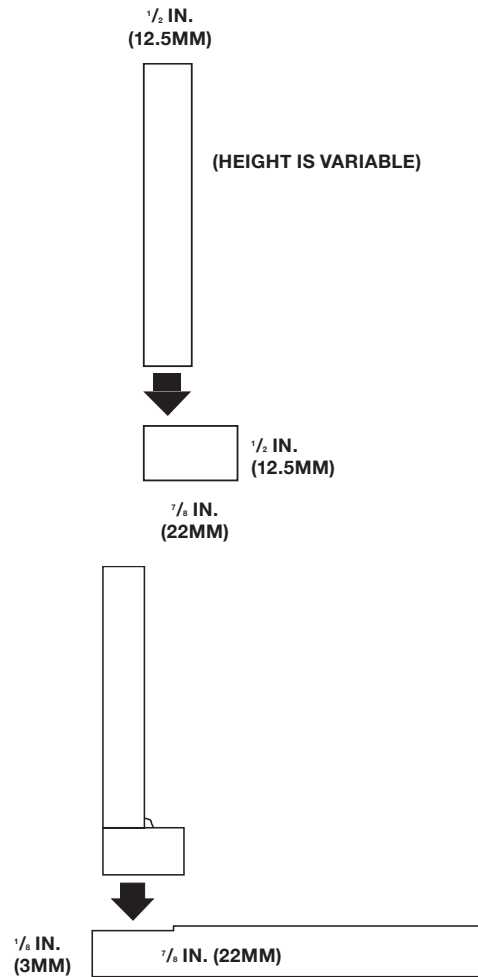

## COVERED BACKSPLASHES USING A COVING ROUTER

### 4. Cut away excess material with a cove router.

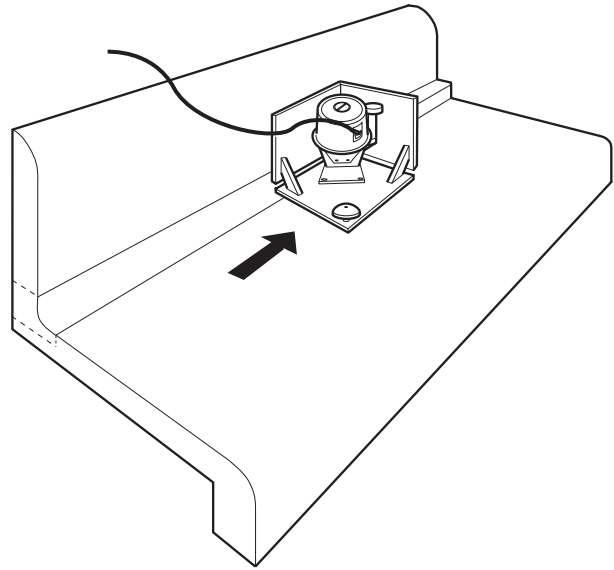

### 5. Finish by sanding.

- Use a cove sander or hand sand with a radiused-edge sanding block.

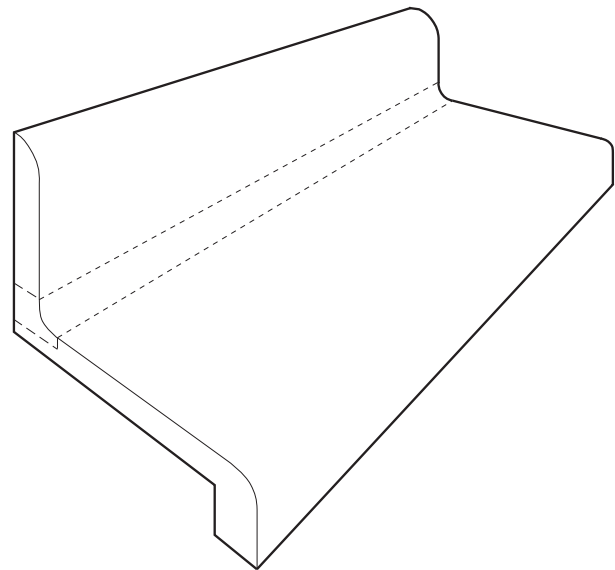

# EVERFORM® SOLID SURFACE FABRICATION GUIDE



## COVERED BACKSPLASHES USING A ROUTER TABLE

### 1. Cut strip of $\frac{1}{2}$ in. material sufficiently wide to provide backsplash and cove piece.

**NOTE:** For typical 4 in. (102mm) high covered splash, a  $5\frac{1}{4}$  in. (133mm) wide strip is required.

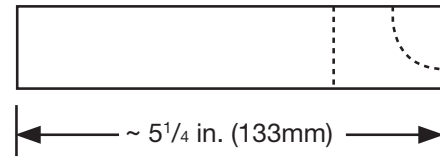

### 2. Rout each of the long sides of strip with a router table set up with a $\frac{1}{2}$ in. double flute carbide cutter and feather boards at both the infeed and outfeed ends of the cutter.

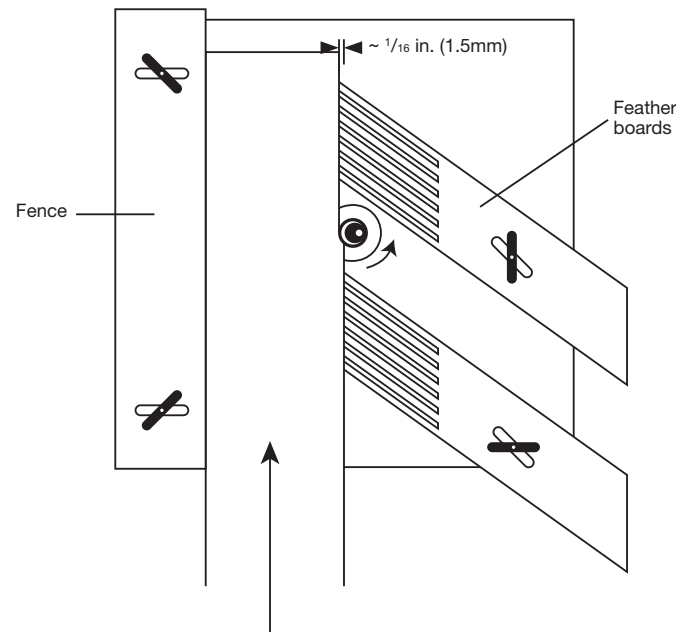

# EVERFORM® SOLID SURFACE FABRICATION GUIDE



## COVERED BACKSPLASHES USING A ROUTER TABLE

### 3. Rout cove into one side of backsplash piece using one of the bits listed below.

- Rout in face-down position.
- For a  $\frac{1}{4}$  in. (6mm) cove radius, use Amana Tool® #45986 carbide bit.
- For a  $\frac{3}{8}$  in. (10mm) cove radius, use Everform® Solid Surface custom carbide bit (file #75719) from Fred M. Velepec Co. (800-365-6636).

Amana Tool® #45986 carbide bit

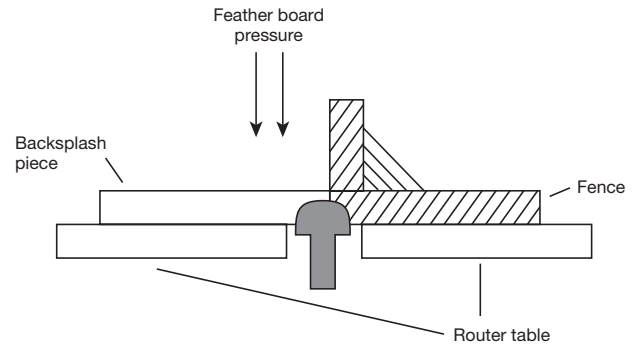

### 4. Separate cove piece from backsplash piece on a table saw.

Typical dimensions for  $\frac{1}{4}$  in. (6mm) cove radius

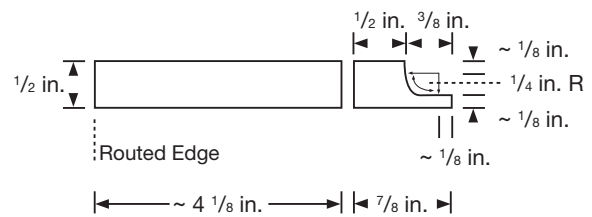

**Cut remaining strip to desired backsplash height. For a 4 in. (100mm) high backsplash, this is typically  $3\frac{5}{8}$  in. (92mm) wide for a  $\frac{1}{4}$  in. (6mm) radius cove and  $3\frac{9}{16}$  in. (90mm) wide for a  $\frac{3}{8}$  in. (10mm) radius cove.**

- Mark non-routed edge to avoid glue line visibility problems later.

Typical dimensions for  $\frac{3}{8}$  in. (10mm) cove radius

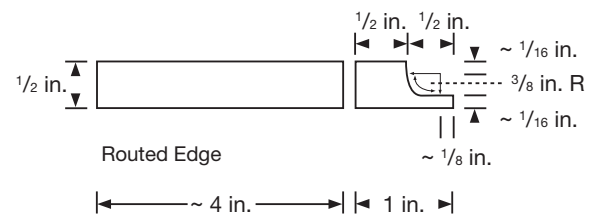

# EVERFORM® SOLID SURFACE FABRICATION GUIDE



## COVERED BACKSPLASHES USING A ROUTER TABLE

### 5. Machine a $\frac{1}{16}$ in. (1.5mm) deep by $\frac{7}{8}$ in. (22mm) wide cut into countertop—covered piece should set slightly higher [ $\frac{1}{64}$ in. (0.4mm)] than deck.

- Round off lower portion of front edge of the cove piece slightly to allow a tighter fit.
- Bond cove piece into countertop using the proper seaming adhesive.

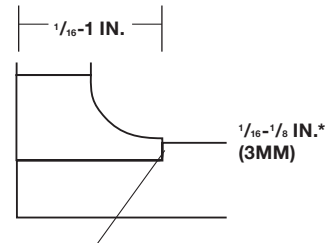

EASE BOT-  
TOM EDGE  
SLIGHTLY

\* Dependent upon cove piece radius.

### 6. Apply spring clamps to create both forward and downward clamping pressure. Check joint line for tightness.

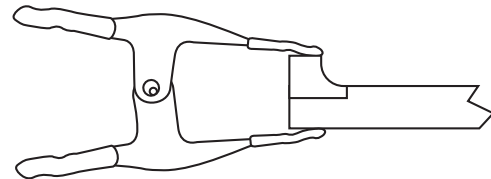

### 7. Dry-fit pre-routed backsplash piece to sanded top of cove—temporarily clamp into exact desired position with adjustable clamps.

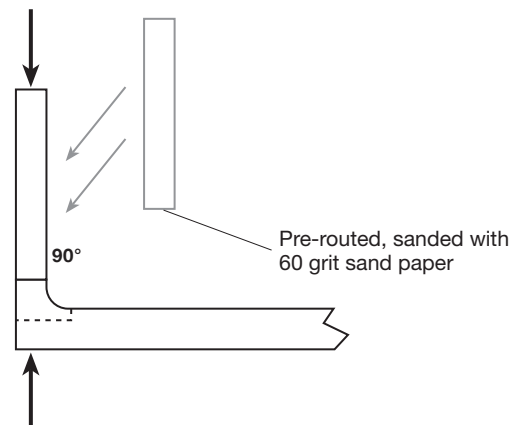

# EVERFORM® SOLID SURFACE FABRICATION GUIDE



## COVERED BACKSPLASHES USING A ROUTER TABLE

**8. Hot melt bond backsplash positioning blocks to the deck at 8-10 in. (203-254mm) intervals. Make sure each fits squarely and tightly to the backsplash piece.**

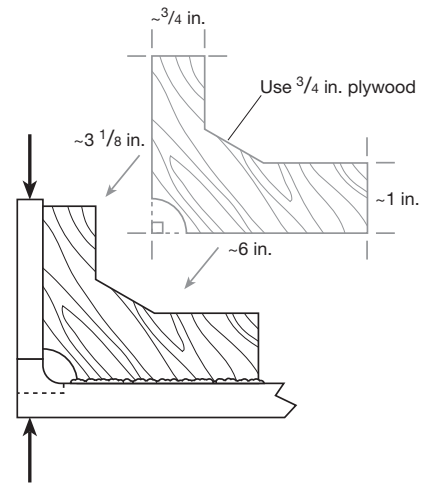

**9. Remove backsplash, sand and clean with alcohol, etc. Apply seaming adhesive and reposition backsplash.**

- Use spring clamps to hold backsplash tight against the positioning block. Apply adjustable clamps to obtain tight joint and squeeze-out.
- Remove excess squeeze-out with a laminate strip or narrow putty knife. Allow adhesive to set.

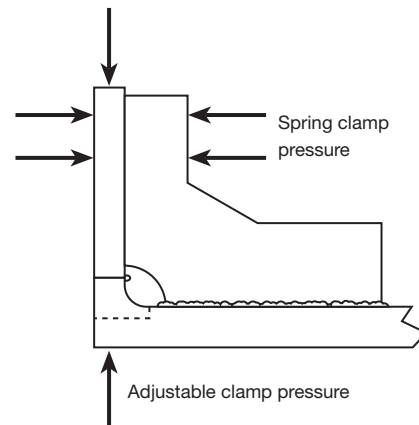

**10. Remove clamps and positioning blocks.**

- Sand cove with a random orbital sander equipped with a soft pad and/or sand by hand with a radiused sanding block.

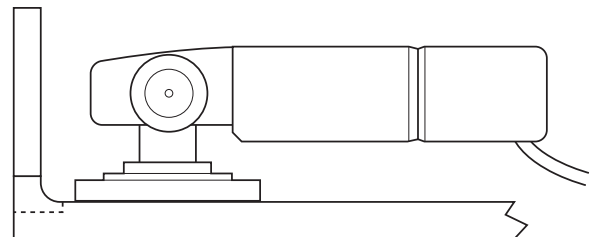



# EVERFORM® SOLID SURFACE FABRICATION GUIDE



## TILED BACKSPLASHES WITH A SILICONE JOINT

### 1. Install countertop.

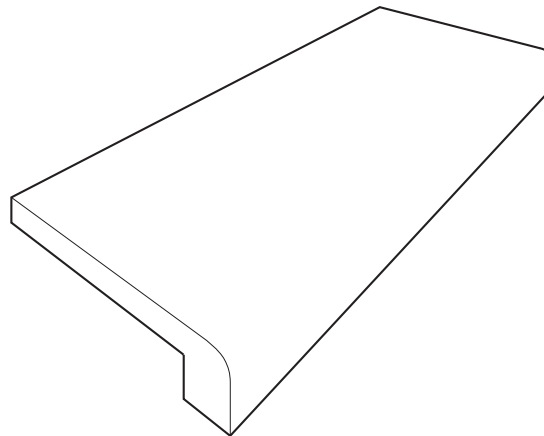

### 2. Attach tile to wall with mortar and grout.

Do not grout down to countertop—leave  $\frac{1}{8}$  in. (3mm) gap between tile and countertop to allow for movement.

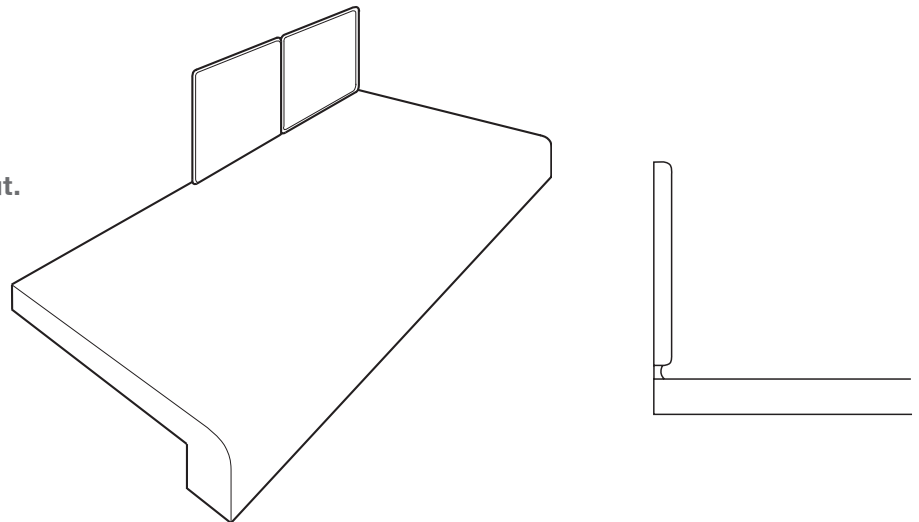

## TILED BACKSPLASHES WITH A SILICONE JOINT CONTINUED

### 3. Apply masking tape to countertop to protect surface from excess silicone.

Fill gap between countertop and tile with 100% silicone.

Remove tape before silicone gels.

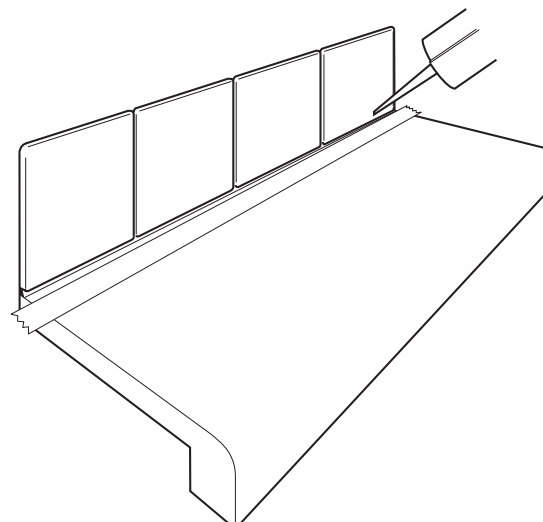

# EVERFORM® SOLID SURFACE FABRICATION GUIDE



## TILED BACKSPASHES WITH A MINI-COVE

**NOTE:** Due to the unique nature of the Artifacts, Mica, and Ice colors, we do not recommend fabrication of a cove backspash. All seams will be extremely visible.

### 1. Pre-cut a ½ in. x 7⁄8 in.\* (12-22mm) cove strip.

- Using a ¼ in. or ⅜ in. (9mm) radius core box bit, rout cove.
- Adjust height to leave about ⅛ in. (3mm) lip.
- Adjust feather board for proper tension.
- \* Width may vary in accordance with tile thickness.

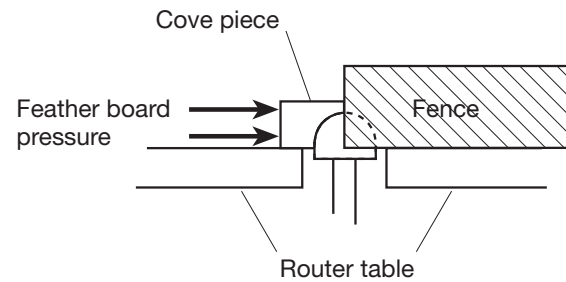

### 2. Mill a ⅛ in. (3mm) deep by 7⁄8 in. (22mm) wide cut into backside of countertop.

- Round off lower front edge of cove piece slightly to allow easier fit.
- Bond cove assembly into countertop using proper seaming adhesive.

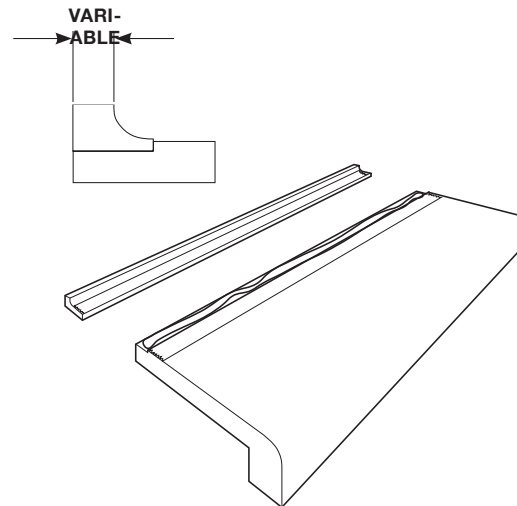

### 3. Apply spring clamps to create both forward and downward clamping pressure. Check joint line for tightness.

- Remove excess adhesive with a laminate chip or putty knife before it cures.
- Finish by sanding flush. Use a cove sander or hand sand with a hard block having a radiused edge.

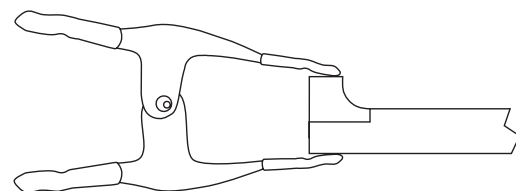

## TILED BACKSPLASHES WITH A MINI-COVE

### 4. Install countertop.

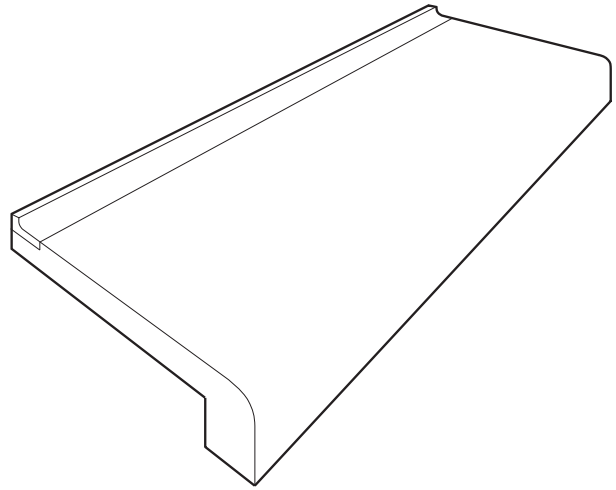

COUNTERTOPS

### 5. Attach tile to wall with mortar and grout.

- Do not grout down to countertop. Leave gap of  $\frac{1}{8}$  in. (3mm) between tile and countertop to allow for movement.
- Fill gap between countertop and tile with silicone.

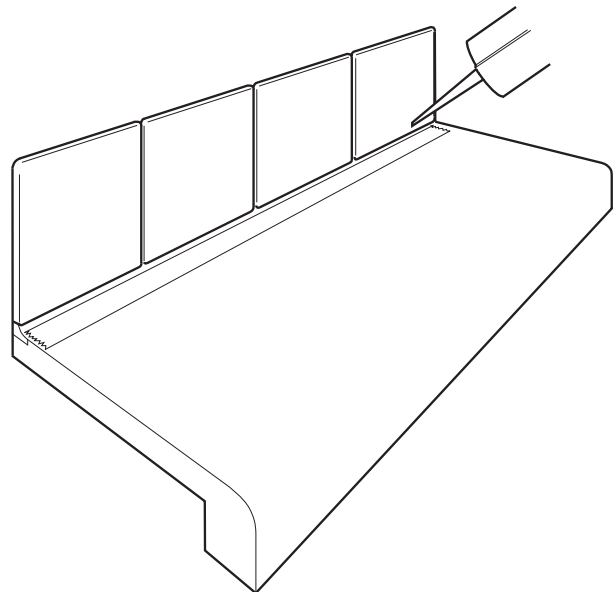

# EVERFORM® SOLID SURFACE FABRICATION GUIDE



## BATHROOMS VISUAL INDEX

BATHROOMS

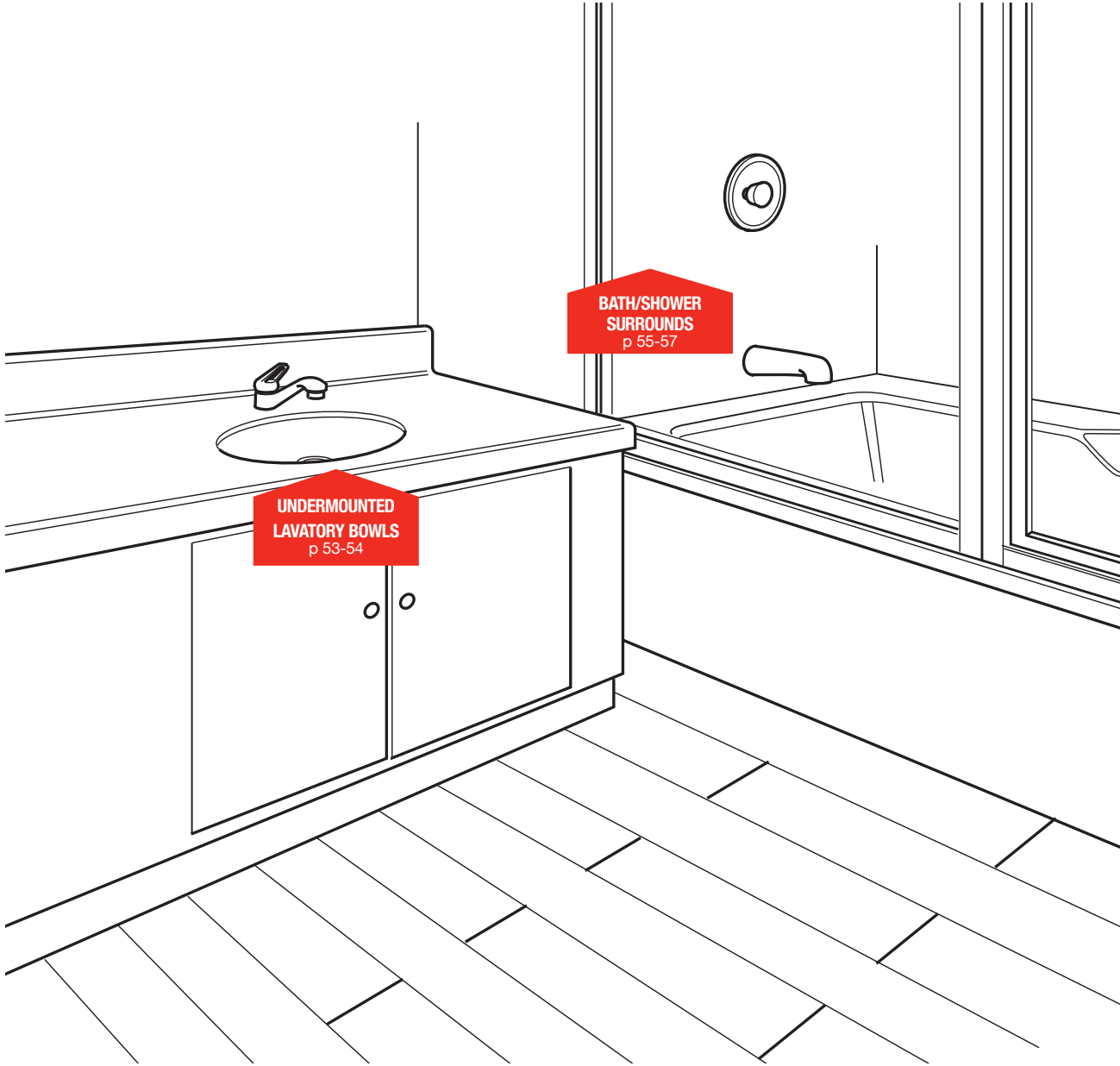

# EVERFORM® SOLID SURFACE FABRICATION GUIDE



## UNDERMOUNTED LAVATORY BOWLS

1. Scratch in center lines for positioning bowl on the backside of countertop with an awl.

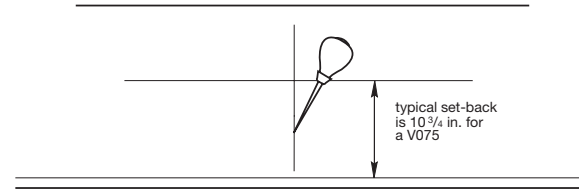

2. Position bowl on top using center-line marks on bowl flange.

- Scratch outside perimeter of bowl into backside of top.

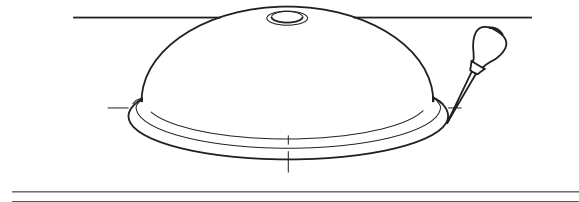

3. Sand bonding area on sheet with 60-grit sandpaper.

- Clean bond area with denatured alcohol.

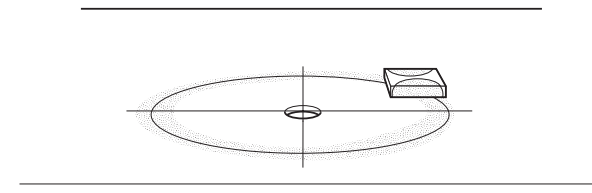

4. Plunge rout a 2-4 in. (50-102mm) diameter venting hole approximately in the center.

- Install hot melt glue blocks to keep sink from moving during gluing operation.

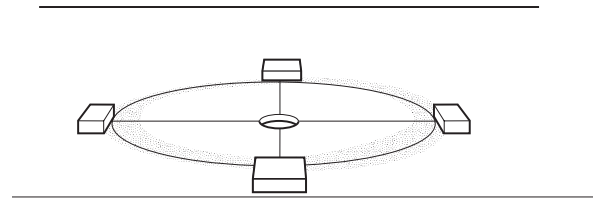

5. Sand bowl flange with 60-grit sandpaper.

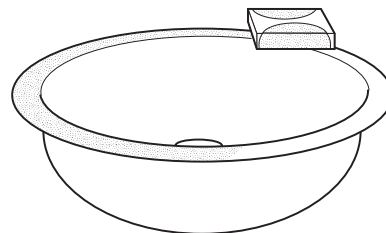

# EVERFORM® SOLID SURFACE FABRICATION GUIDE



## UNDERMOUNTED LAVATORY BOWLS

### 6. Clean flange with denatured alcohol and a clean white rag.

- Allow to dry.

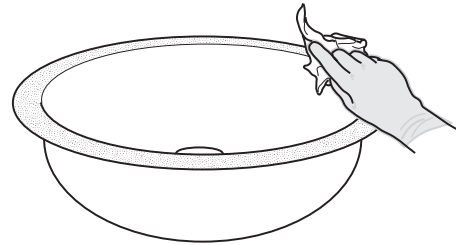

### 7. Apply a ¼ in. (6mm) or larger bead of Everform® Solid Surface seaming adhesive to flange—color should be same as bowl.

- Do not spread bead.
- Invert bowl and press into place with slight movement to transfer adhesive.
- Bowl must be set in place within two minutes after applying adhesive.

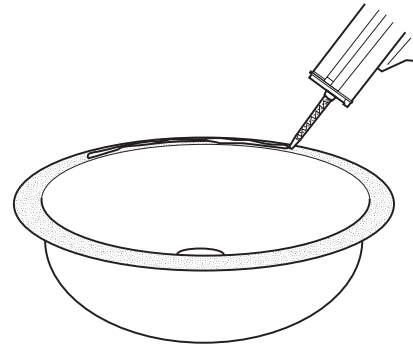

### 8. Clamp the perimeter of the bowl with adjustable deep throated clamps and wood strips.

- Allow adhesive to cure.

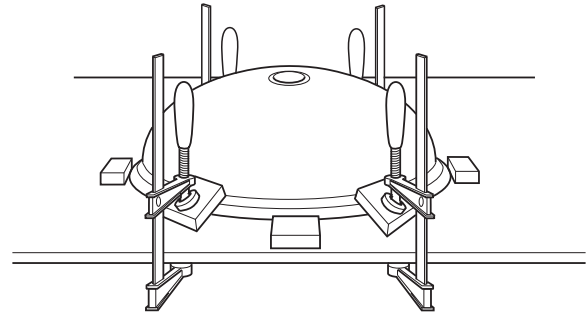

### 9. Remove clamps, and turn lavatory top right side up onto a sturdy support.

- Use a carbide cutter bit to cut out sink opening.
- Catch cutout to avoid damage.

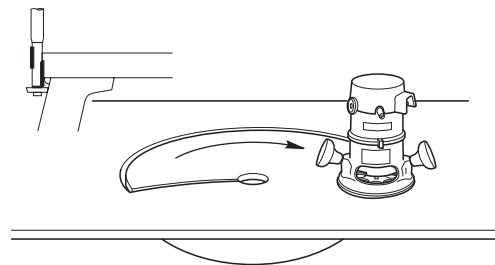

### 10. For a round-over edge, use carbide round-over cutter bit to shape bowl lip.

**NOTE:** If mounting a V065 or V075 model sink, a special round-over bit is required.

- Finish sand to blend with rest of top.

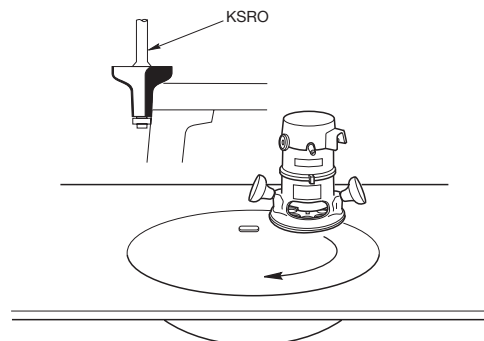

# EVERFORM® SOLID SURFACE FABRICATION GUIDE



## BATH SURROUNDS

Everform® Solid Surface is available in ¼ in. (6mm) thickness for vertical wet wall applications.

### 1. Pre-cut and dry fit Everform® Solid Surface ¼ in. sheet stock.

- Apply ¼ in. (6mm) beads of clear silicone to back wall along the perimeter of sheet and at 6-8 in. (152-203mm) intervals.
- Apply sheet leaving a gap of ¼ in. (3mm) above tub and between sheets. Brace as necessary until silicone cures.
- Do not bond directly to studs... must be clad with water resistant drywall or cement board.
- To assure a good bond and to minimize telegraphing, pre-coat cement board or water resistant drywall with a white or off-white drywall primer.

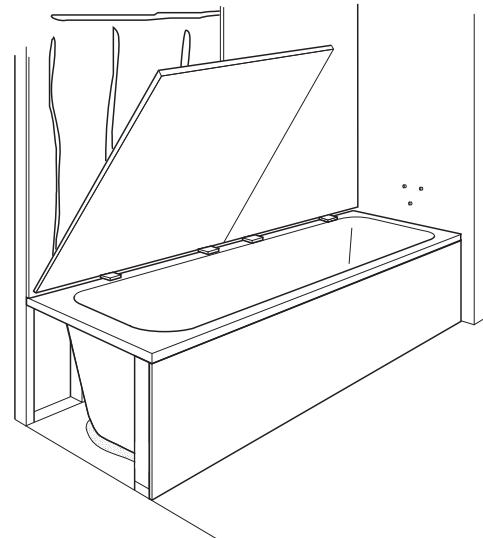

### 2. Pre-cut faucet holes in end panel with a hole saw or router. Smooth edges with sandpaper to remove any chips.

- Apply beads of clear silicone to walls and adhere panel. Brace as necessary until silicone cures.

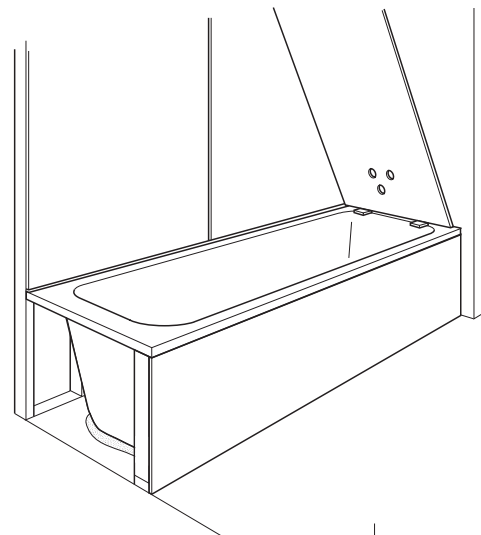

### 3. Caulk all gaps with color matched silicone.



# EVERFORM® SOLID SURFACE FABRICATION GUIDE



## BATH SURROUNDS

- 4. Apply beads of color matched silicone to all vertical and corner joints.**

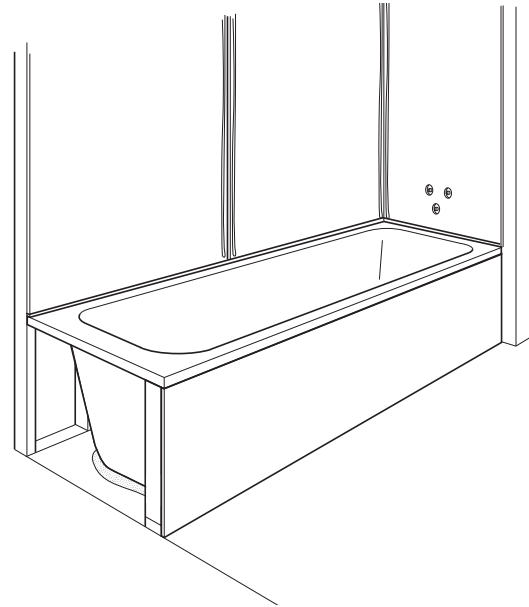

- 5. If desired, cap moldings, batten strips and corner moldings can be fabricated from ¼ in. (6mm) and/or ½ in. (12.5mm) sheet stock. Adhere with silicone. Do not use the seaming adhesive.**

- Tape in position until silicone cures.

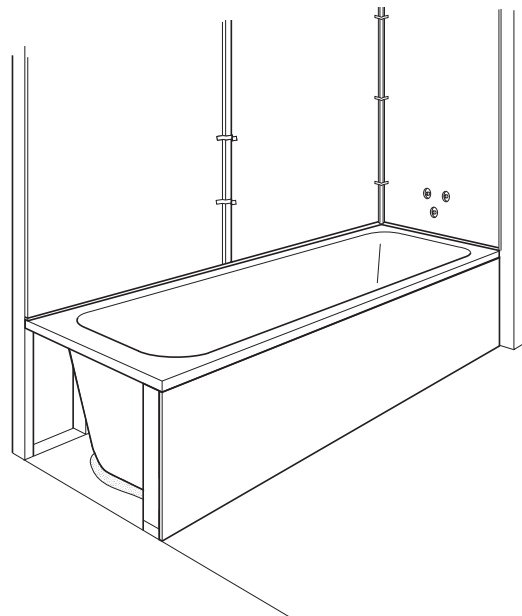

**NOTE:** The use of a batten strip panel can be avoided by hard seaming the two ¼ in. (6mm) thick back panels together. Reinforce the back side with a 2-3 in. (50-76mm) wide strip of ¼ in. (6mm) material that has been chamfered on both sides. Bond with the seaming adhesive. Cut out and remove a portion of the dry wall directly behind the seam reinforcement strip.



# EVERFORM® SOLID SURFACE FABRICATION GUIDE



## SHOWER SURROUNDS

**Everform® Solid Surface is available in 1/4 in. thick sheet stock for vertical wet wall applications.**

**1. Pre-cut and dry fit Everform® Solid Surface 1/4 in. (6mm) sheet stock. Provide a 1/8 in. (3mm) gap between sheets, in the corners and above the shower pan. Cut holes for plumbing fixtures with a hole saw or router. Smooth edges of holes with sandpaper to remove any chips.**

- Do not bond directly to studs—must bond to water resistant drywall or cement board.
- To assure a good bond and to minimize telegraphing, pre-coat cement board or water resistant drywall with a white or off-white drywall primer.

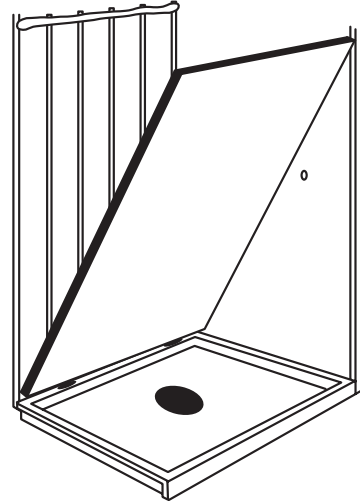

**2. Apply beads of clear silicone along perimeter and at 6-8 in. intervals to the wall. Run a circular bead of clear silicone around all fixture openings. Tip panels into place—brace as necessary until silicone cures.**

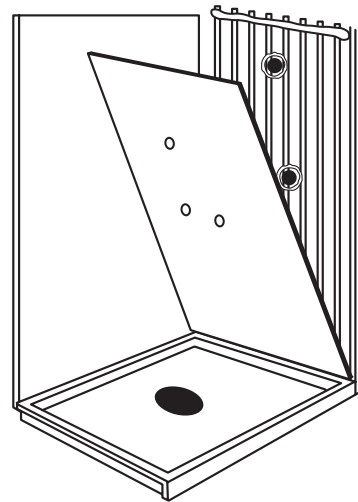

**3. Apply color matched silicone to all joints.**

- Corner, edge and cap moldings can be custom fabricated from 1/4 or 1/2 in. (6 mm or 12 mm) Everform® Solid Surface sheet stock. Adhere with silicone. Do not use seaming adhesive. Tape moldings in place until silicone cures.

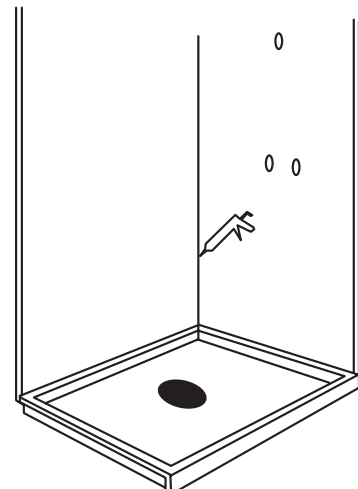

# EVERFORM® SOLID SURFACE FABRICATION GUIDE



## COMMERCIAL VISUAL INDEX NURSE'S STATIONS

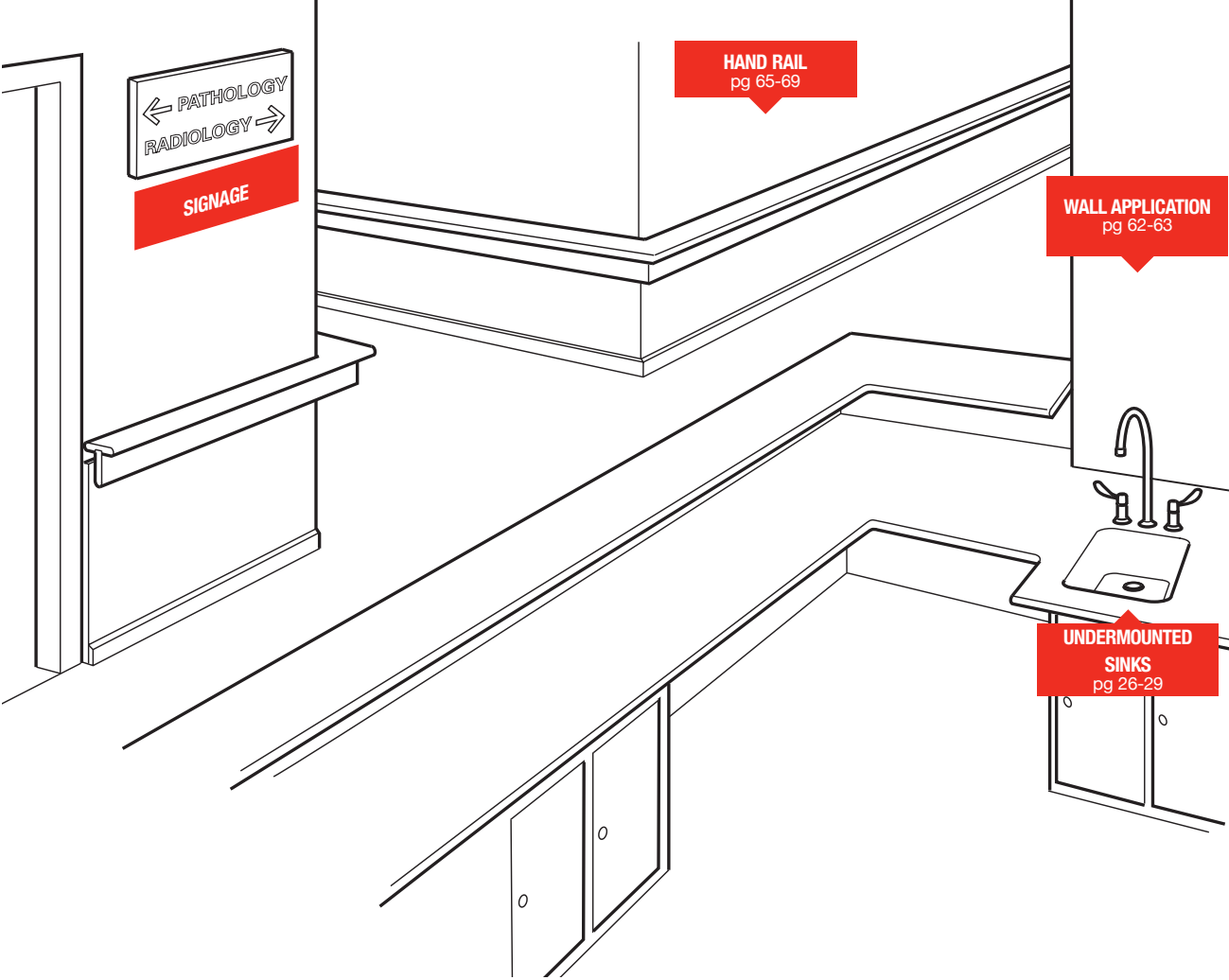

COMMERCIAL

# EVERFORM® SOLID SURFACE FABRICATION GUIDE



## COMMERCIAL VISUAL INDEX LOBBIES

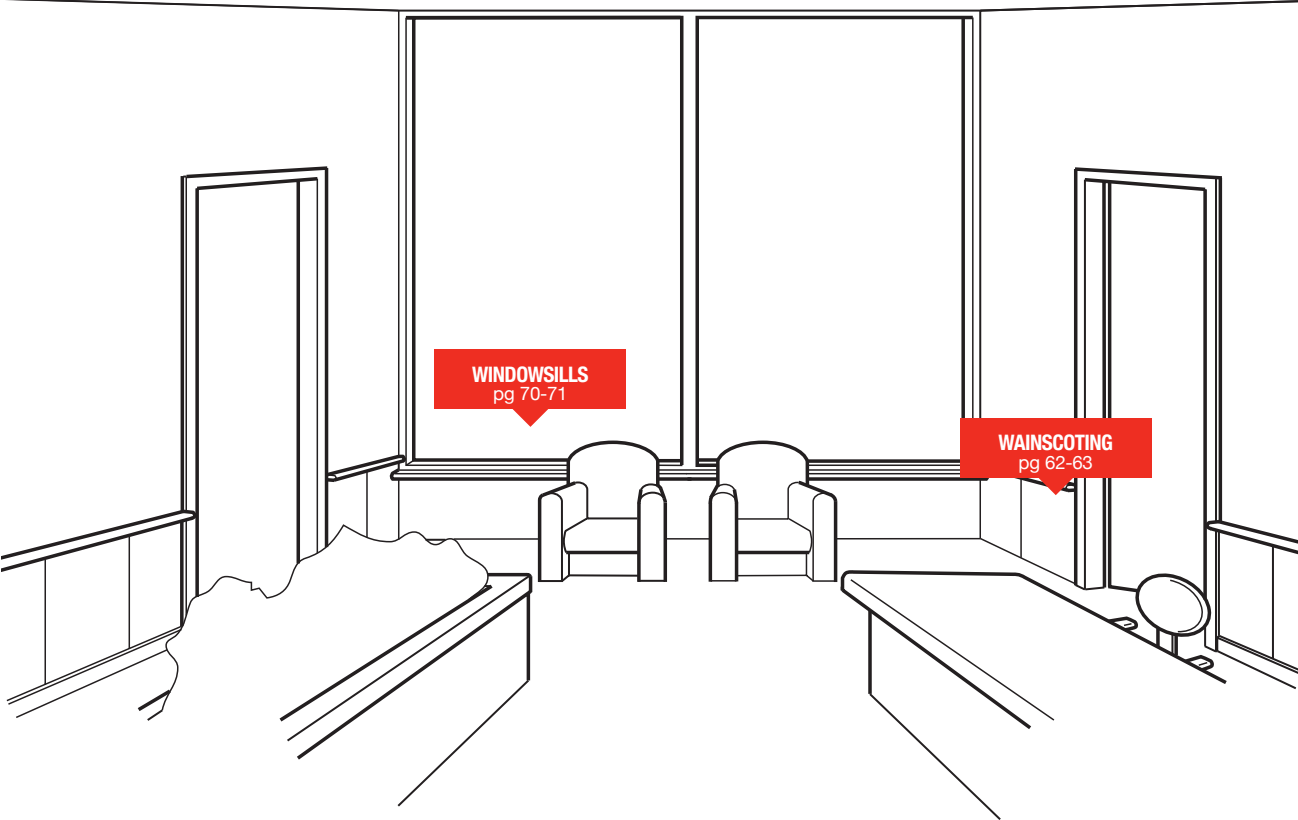

COMMERCIAL

# EVERFORM® SOLID SURFACE FABRICATION GUIDE



## COMMERCIAL VISUAL INDEX BATHROOMS

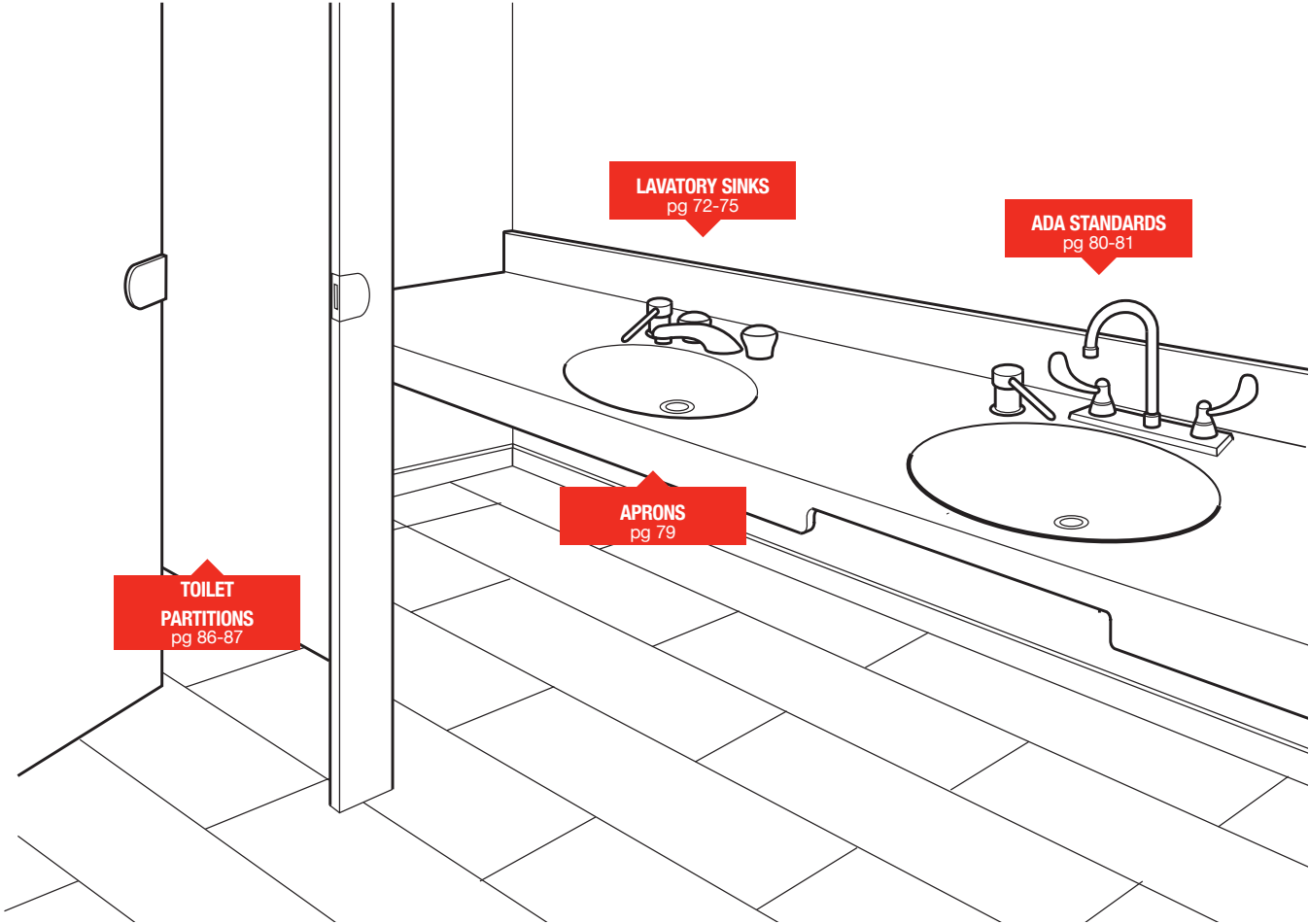

# EVERFORM® SOLID SURFACE FABRICATION GUIDE



## COMMERCIAL VISUAL INDEX RESTAURANTS

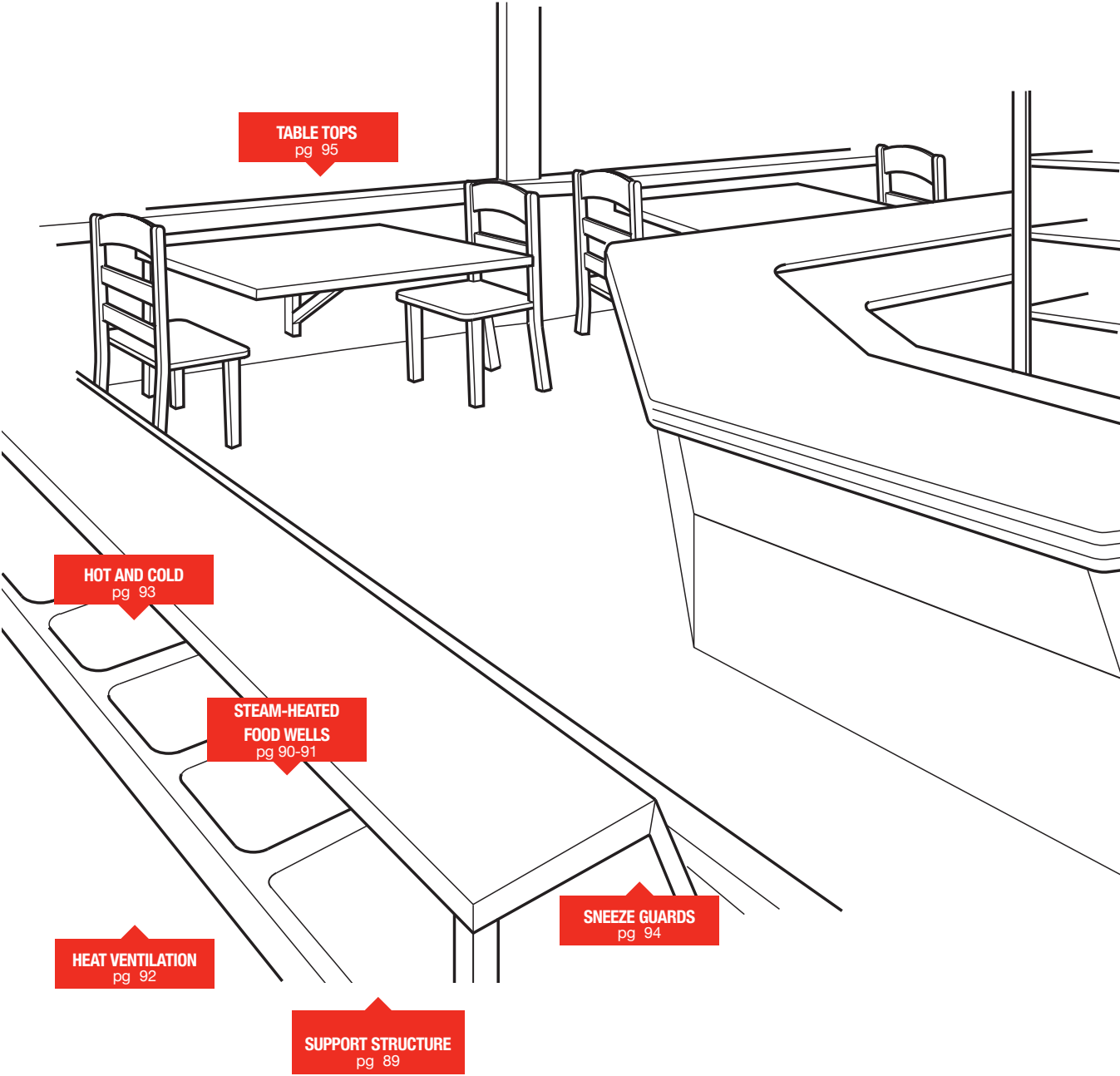

COMMERCIAL

# EVERFORM® SOLID SURFACE FABRICATION GUIDE



## WALL APPLICATION PANELS/WAINSCOTING

**NOTE:** Everform® Solid Surface is available in ¼ in. (6mm) thicknesses for wall and vertical applications. If greater impact resistance is required, ½ in. (12.5mm) thick material can be used.

### 1. Install ½ in. (12.5mm) or ¾ in. (18mm) thick Everform® Solid Surface baseboard to wall with silicone.

- Allow to cure.

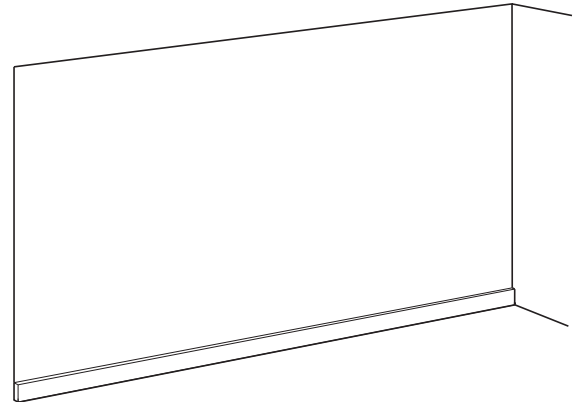

### 2. Place ⅛ in. (3 mm) shims on baseboard to allow for gap between panel and baseboard.

- Dry fit sheet.
- Leave ⅛ to ¼ in. (1.5 to 3mm) gap between abutting panels for expansion.
- Apply beads of clear silicone to wall along the perimeter of sheet and at 6 in. (152mm) to 8 in. (203mm) intervals. Brace or use hot melt adhesive to hold in position until the silicone cures.

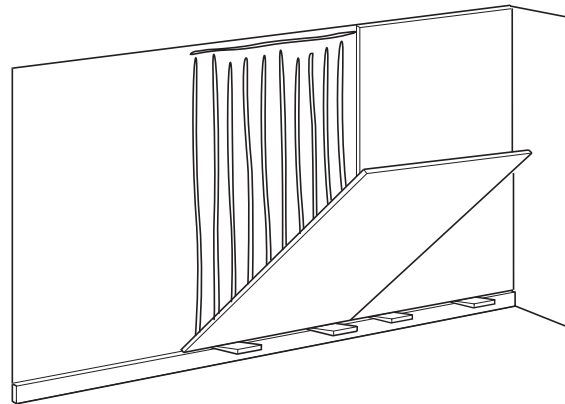

### 3. Should applied sheets lift at edges, temporary cleats or bracing may be used to hold in position until silicone cures.

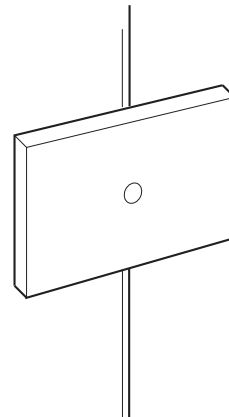

# EVERFORM® SOLID SURFACE FABRICATION GUIDE



## WALL APPLICATION PANELS/WAINSCOTING

### 4. Remove 1/8 in. (3mm) spacers and temporary cleats.

- Apply a bead of color matched silicone between panels and at the baseboard junction.
- A slight chamfer on each side of gapped butt joint will make caulking easier as the silicone bead can be recessed slightly. This also helps to make slight surface misalignment less noticeable.

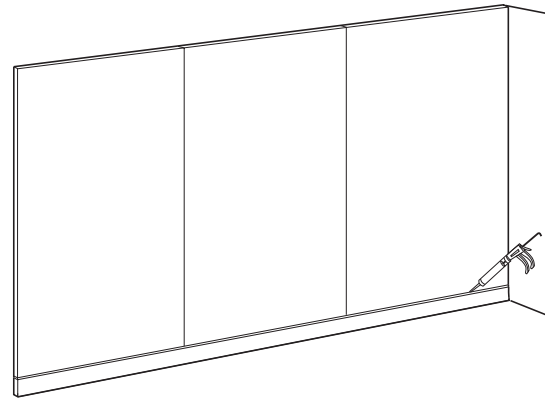

### 5. If wall panels are not full height, a wood cap molding may be used. Nail directly through the wood and into the studs. Do not nail through the solid surfacing panels.

- Cap moldings can also be fabricated from 1/2 in. (12.5mm) Everform® Solid Surface material-rabbit as necessary.

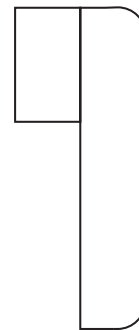

### 6. If installing cap moldings, apply a bead of silicone.

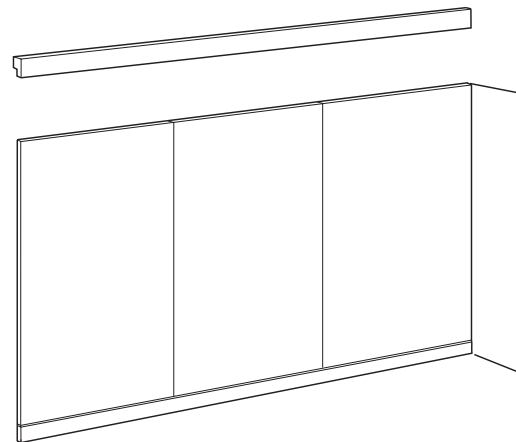

### 7. Position cap rail over top edge of panel and tape or hot melt into place.

- Remove excess silicone.
- Allow silicone to cure.

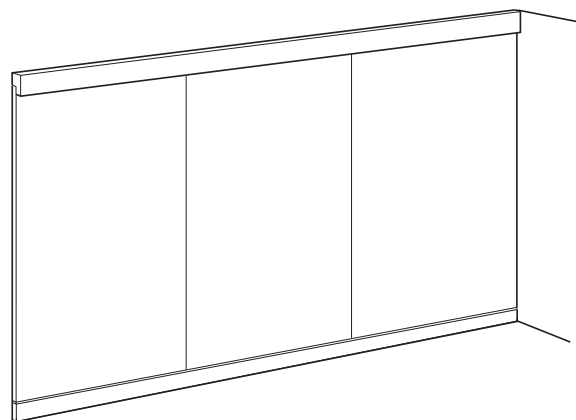

# EVERFORM® SOLID SURFACE FABRICATION GUIDE



## WALL APPLICATION CORNER TREATMENTS

**1. Fabricate a custom corner from one or two pieces of Everform® Solid Surface material. Bond together with seaming adhesive— profile and finish.**

- Install with color matched silicone.

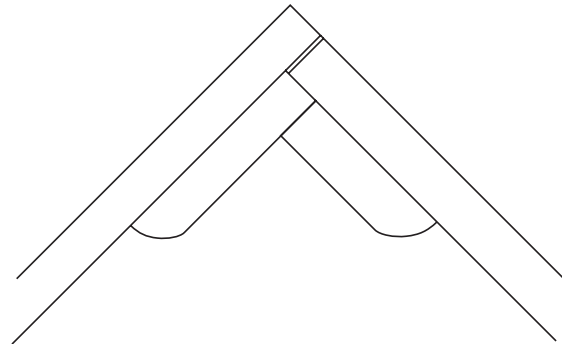

**2. Another option is to caulk corner joint with color matched silicone.**

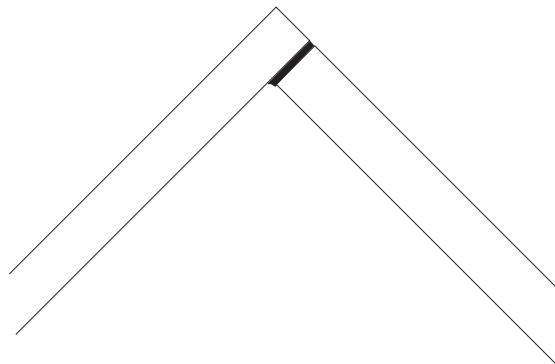

COMMERCIAL



# EVERFORM® SOLID SURFACE FABRICATION GUIDE



## HAND RAIL STANDARD

1. Prepare rail by fusing two pieces of Everform® Solid Surface together with seaming adhesive.

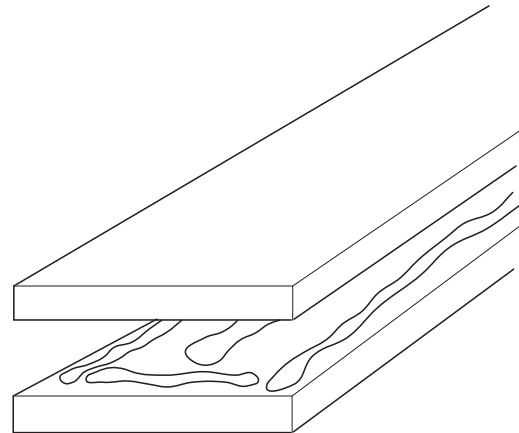

2. Trim edges and profile as desired.

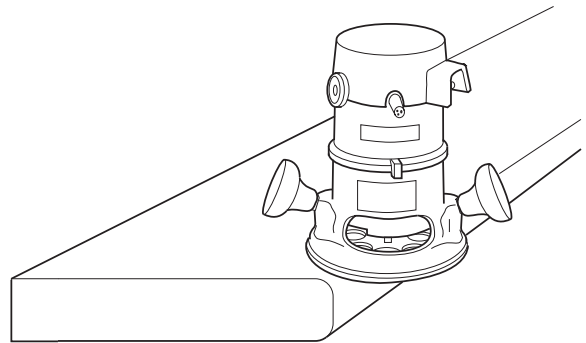

3. Attach wall mounting bracket to wall.

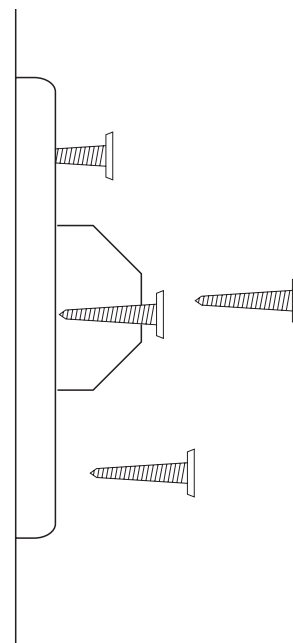

## HAND RAIL STANDARD

### 4. Drill holes for hardware.

- Insert bolt and other necessary hardware through hand rail.
- The hole for the bolt should be about  $\frac{1}{16}$  in. (1.5mm) oversized to allow for movement.

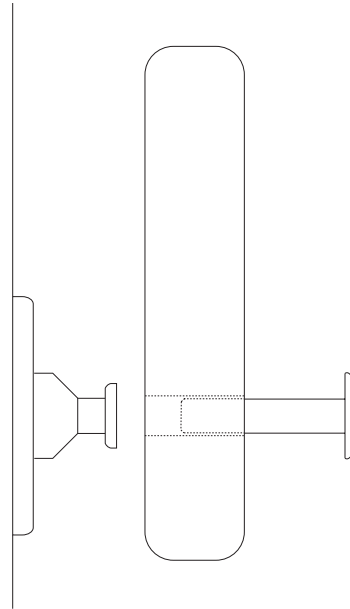

### 5. Tighten all hardware.

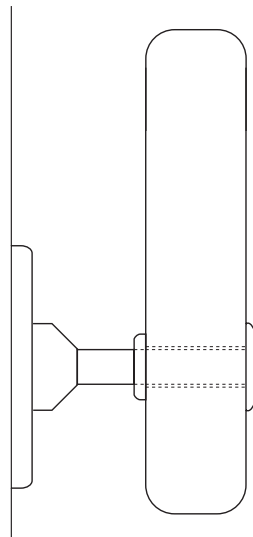

# EVERFORM® SOLID SURFACE FABRICATION GUIDE



## HAND RAIL T-CAPPED RAIL

**1. Prepare rail cap by cutting  $\frac{1}{8}$  in. (3mm) deep groove into a strip of Everform® Solid Surface.**

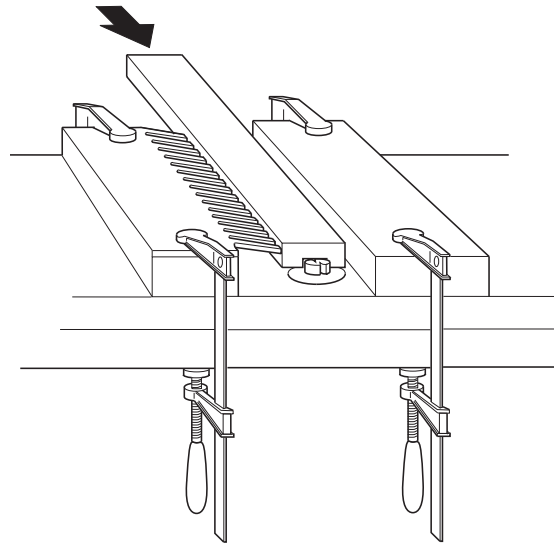

**2. Ease over each edge as desired.**

- Sand to remove chatter, etc.

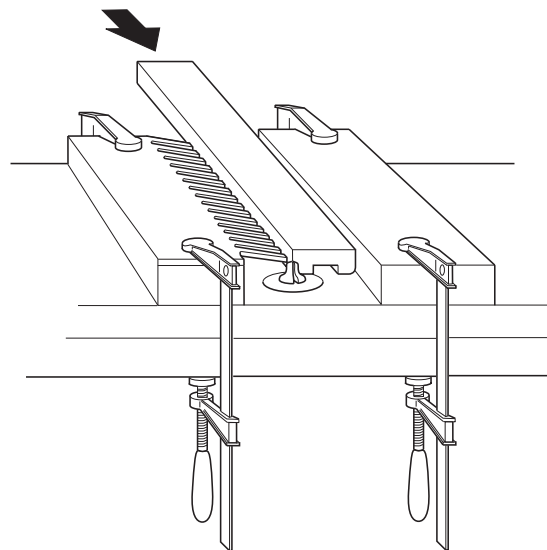

**3. Bond two pieces of  $\frac{1}{2}$  in. (12.5mm) material together with seaming adhesive if a thicker rail is desired. Clamp until adhesive sets.**

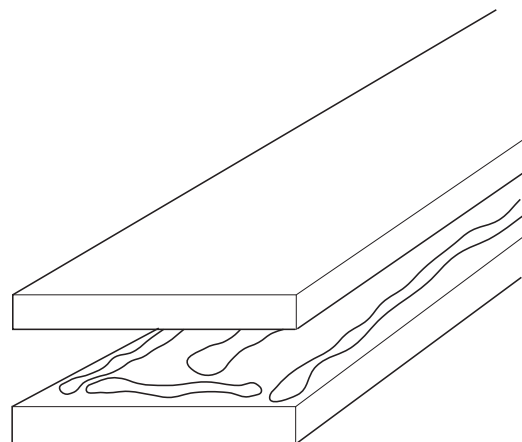

# EVERFORM® SOLID SURFACE FABRICATION GUIDE



## HAND RAIL T-CAPPED RAIL

**4. Trim both sides and then profile bottom edges as desired.**

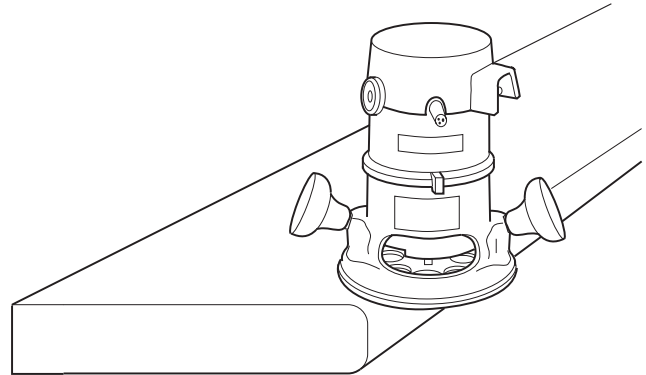

**5. Bond rail cap to bottom piece with seaming adhesive. Clamp. Remove excess adhesive. Allow to cure.**

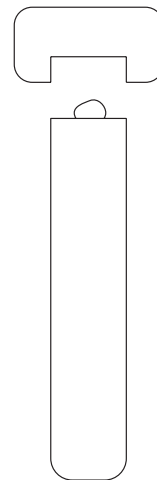

**6. Attach mounting bracket to wall.**

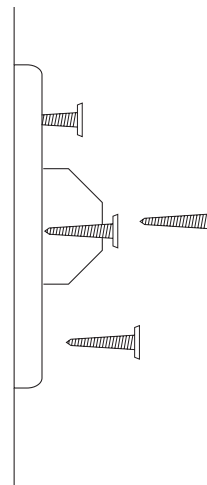

# EVERFORM® SOLID SURFACE FABRICATION GUIDE



## HAND RAIL T-CAPPED RAIL

### 7. Drill holes for hardware.

- Insert bolt and other necessary hardware through hand rail.
- The hole for the bolt should be about  $\frac{1}{16}$  in. (1.5mm) oversized to allow for movement.

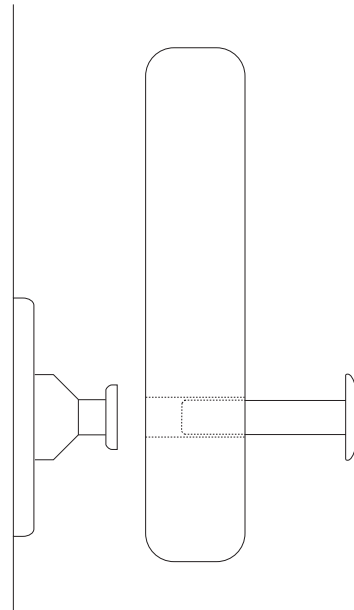

### 8. Tighten all hardware.

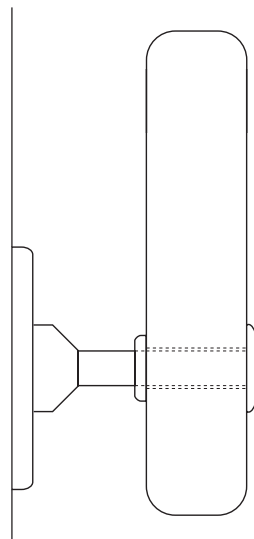

# EVERFORM® SOLID SURFACE FABRICATION GUIDE



## WINDOWSILLS

### 1. Prepare Everform® Solid Surface windowsill with desired edge treatment.

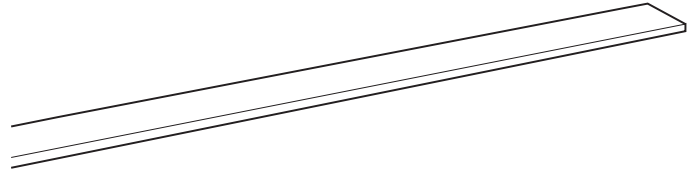

### 2. Make cutouts where needed for mullions, etc.

- Make cutouts oversized to allow for expansion and contraction. A 10 ft. (305cm) long sill will expand or contract about 1/8 in. (3mm) with a 50°F (10°C) temperature increase or decrease. Greater temperature changes will require more clearance.
- Radius inside corners a minimum of 1/4 in. (6mm).

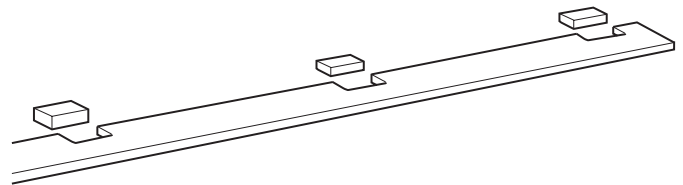

COMMERCIAL

### 3. Apply silicone and install windowsill.

- Support may be plywood, cement board or other waterproof material. Do not use particle board.

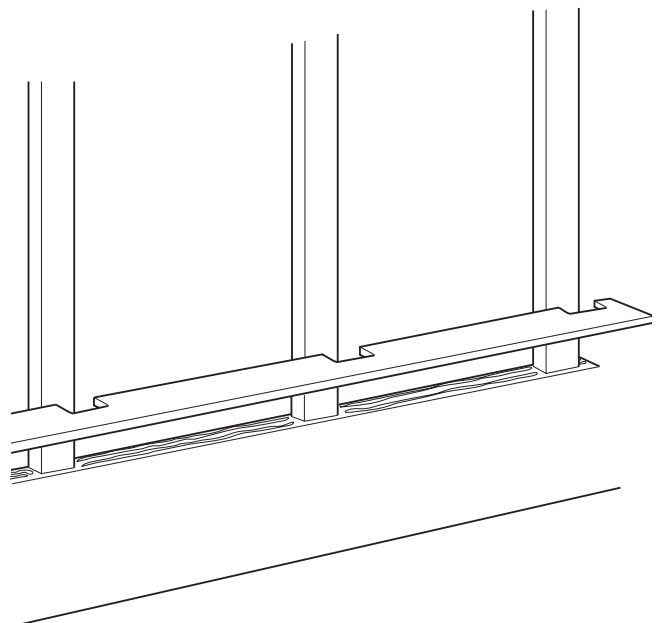

## WINDOWSILLS

4. Caulk with color matched silicone.

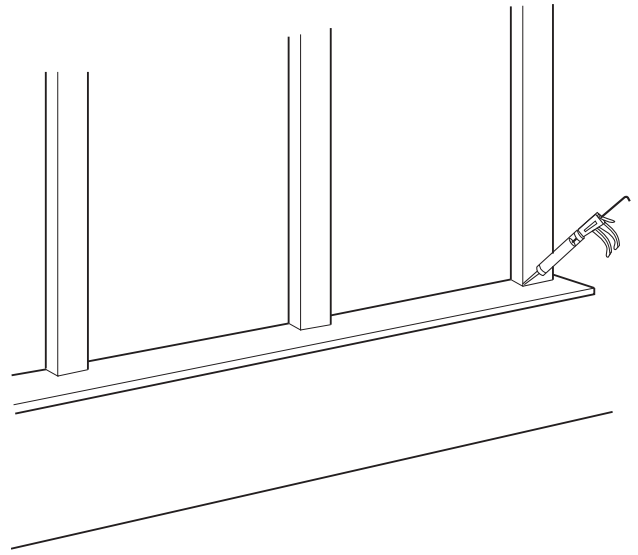

# EVERFORM® SOLID SURFACE FABRICATION GUIDE



## KNEE WALLS

**1. Rough in knee wall with 2x4s.**

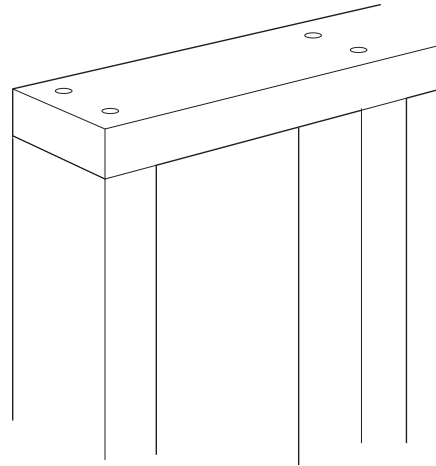

**2. Apply drywall to both sides. Tape joints and apply drywall primer.**

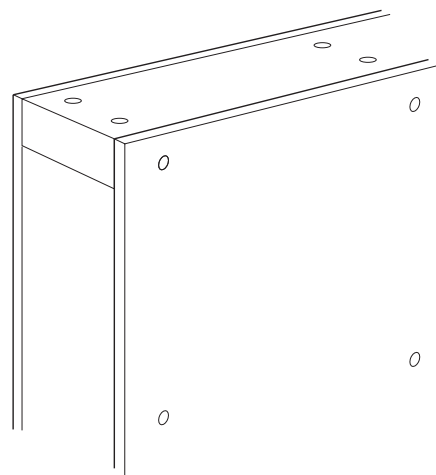

**3. If facing wall with Everform® Solid Surface panels, apply beads of silicone to wall.**

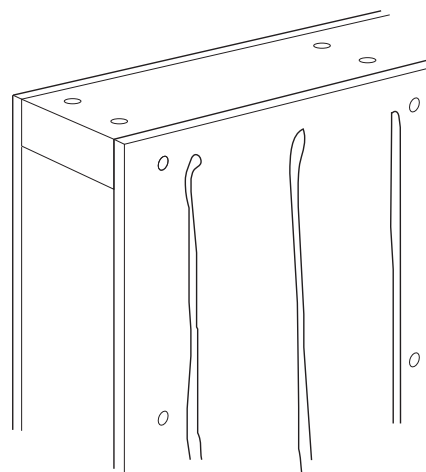



## KNEE WALLS

### 4. Apply wall panels.

- Brace if necessary until silicone cures.

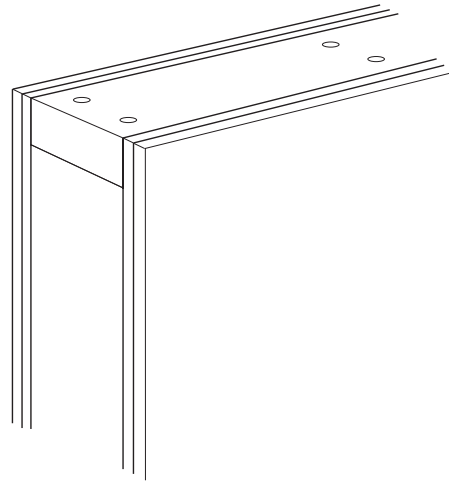

### 5. Fasten a plywood cap onto knee wall.

- Shim as necessary to make level and straight.

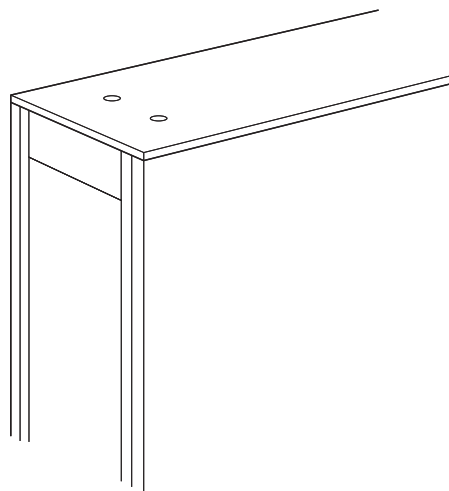

### 6. Fabricate a Everform® Solid Surface knee wall cap with drop edges.

- Inside dimension of cap should be  $\frac{1}{8}$  in. (3mm) larger than width of wall to avoid binding.

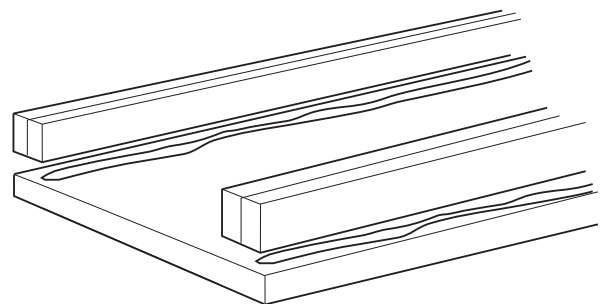

# EVERFORM® SOLID SURFACE FABRICATION GUIDE



## KNEE WALLS

7. Profile and finish the edge as desired.

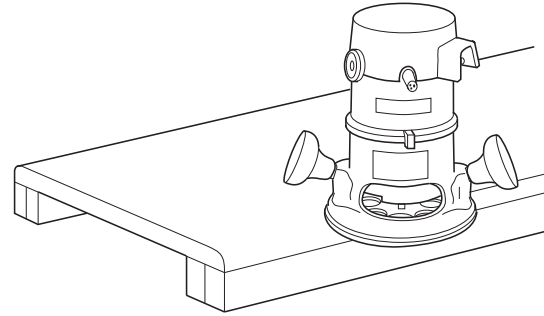

8. Nail  $\frac{3}{4}$ -1 in. (19-25.5MM) wide by  $\frac{1}{8}$ - $\frac{1}{4}$  in. (3-6mm) thick strips of luan to both sides of cap.

- Apply dabs of silicone at 12-18 in. (305-457mm) intervals on each side.

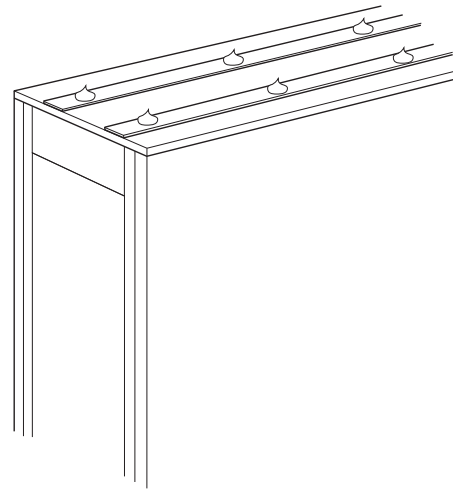

9. Install knee wall cap. Allow silicone to cure.

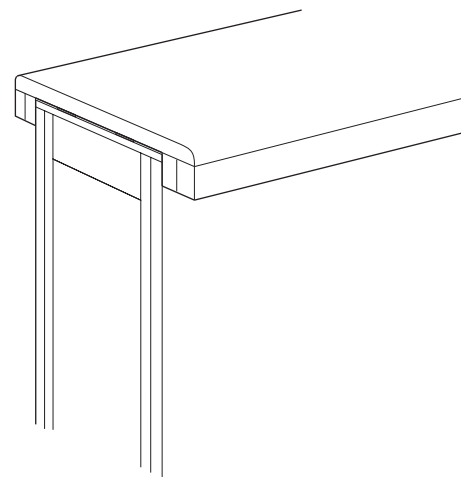

# EVERFORM® SOLID SURFACE FABRICATION GUIDE



## LAVATORY TOPS

### INSTALLATION BETWEEN END WALLS

#### 1. Using 2x4s, build support frame utilizing existing walls.

- Attach to back and end wall studs.
- Use a cross support member between each sink or every 36 in. (914mm).

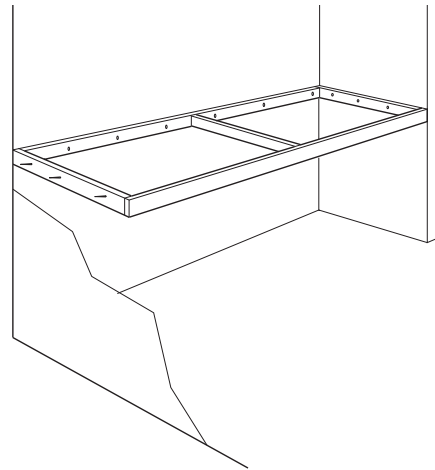

#### 2. Place dabs of silicone in strategic locations along framework every 12-18 in. (305-457mm).

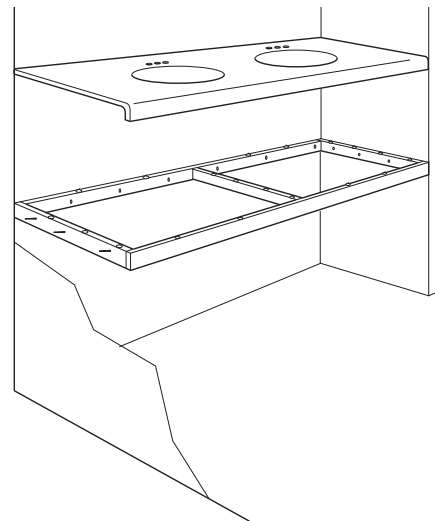

#### 3. Set lavatory top into position.

- Lavatory top should be undersized to accommodate expansion. Allow  $\frac{1}{8}$  in. (3mm) for each ten feet of length for each 50°F (10°C) temperature increase.

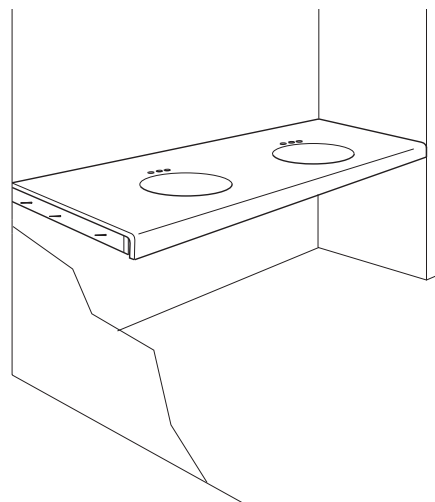

# EVERFORM® SOLID SURFACE FABRICATION GUIDE



## LAVATORY TOPS INSTALLATION BETWEEN END WALLS

### 4. Install backsplash with silicone.

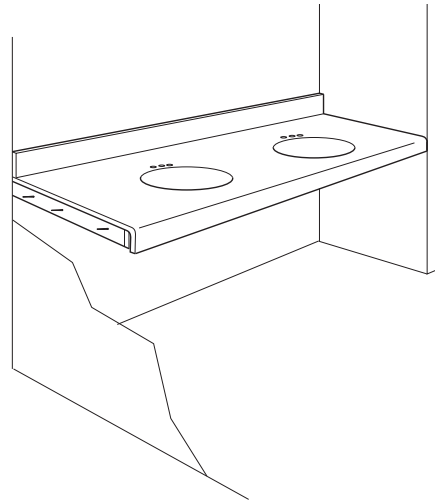

# EVERFORM® SOLID SURFACE FABRICATION GUIDE



## LAVATORY TOPS

### INSTALLATION WITHOUT END WALL SUPPORT

#### 1. Attach brackets to wall.

- Brackets should be placed at each end and between each bowl or every 36 in. (914mm).

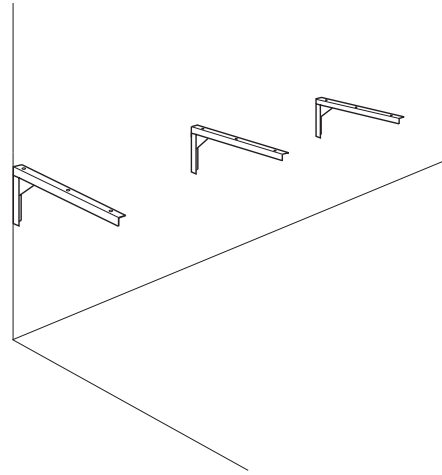

#### 2. Construct support frame and fasten to wall brackets.

- Use a support member between each bowl or every 36 in. (914mm).

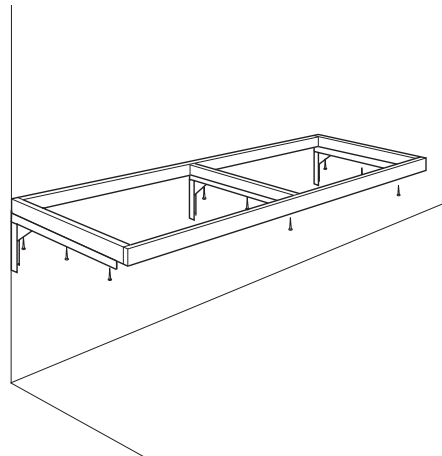

#### 3. Place dabs of silicone at 12-18 in. (305-457mm) intervals along framework.

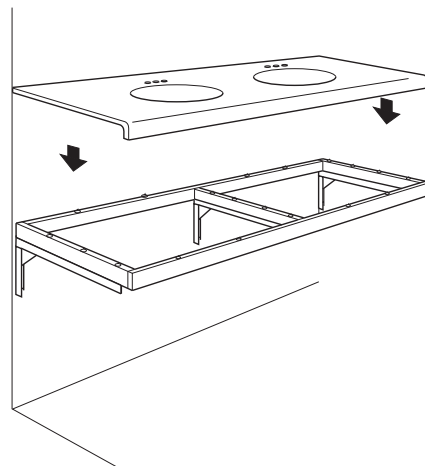

# EVERFORM® SOLID SURFACE FABRICATION GUIDE



## LAVATORY TOPS INSTALLATION WITHOUT END WALL SUPPORT

**4. Install lavatory top into position.**

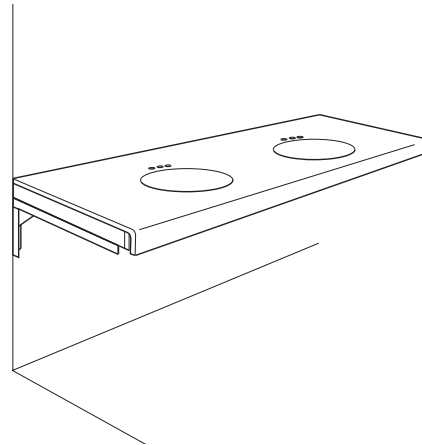

**5. Install backsplash with silicone.**

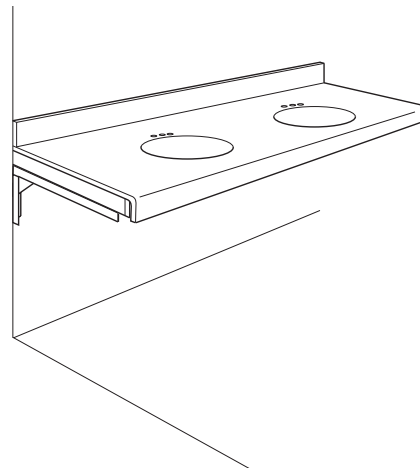

COMMERCIAL

# EVERFORM® SOLID SURFACE FABRICATION GUIDE



## LAVATORY TOPS APRON OPTIONS

### 1. Thick profile with rigid joint.

- 8 in. (203mm) maximum apron for rigid joint.
- Apply dabs of silicone along front at 8-12 in. (203-304mm) intervals.

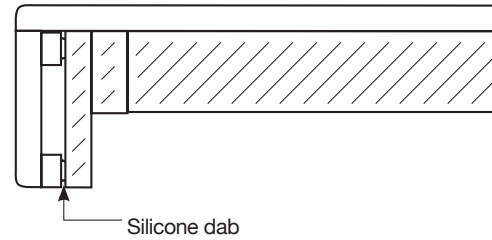

### 2. Hidden flexible joint.

- Adhere to front support frame with silicone.

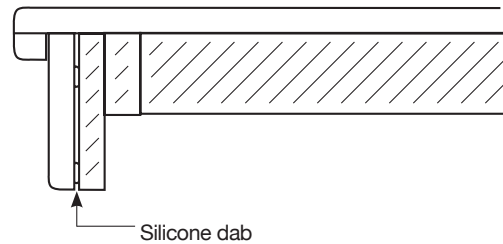

### 3. Set back flexible joint.

- adhere to front support frame with silicone.

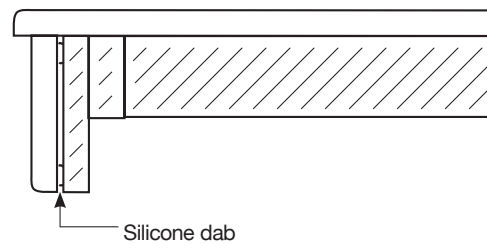

# EVERFORM® SOLID SURFACE FABRICATION GUIDE



## ADA STANDARDS

### HANDICAPPED ACCESSIBLE LAVATORY TOPS

Everform® Solid Surface lavatory bowls, with the over-flow located at the back, can be fabricated and installed to comply with the height, clearance and floor space requirements of The Americans with Disabilities Act (ADA) for handicapped accessibility. The following outlines these requirements as of May 2006. Check current ADA standards at [www.usdoj.gov/crt/ada](http://www.usdoj.gov/crt/ada). Sketches for bowls undermounted on standard 19 in. and 22 in. decks are illustrated on pages 87-88.

#### 1. Height and Clearances

- Lavatories shall be mounted with the rim or counter surface no higher than 34 in. (865mm) above the finish floor. Provide a clearance of at least 29 in. (735 mm) from the finish floor to the bottom of the apron. Knee and toe clearance shall comply with drawing to the right.

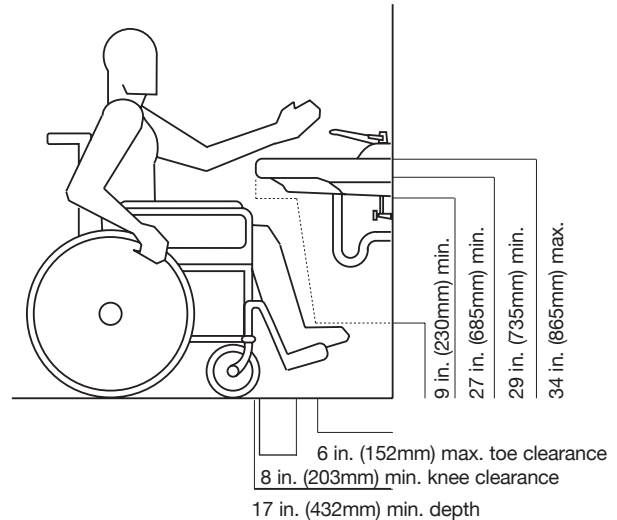

#### Clear Floor Space

- A clear floor space 30 in. by 48 in. (760mm by 1220 mm) shall be provided in front of a lavatory to allow forward approach. Such clear floor space shall be provided within an accessible bathroom. The clear floor spaces at fixtures and controls, the accessible route, and the turning space may overlap.

#### Exposed Pipes and Surfaces

- Hot water and drain pipes under lavatories shall be insulated or otherwise configured to protect against contact. There shall be no sharp or abrasive surfaces under lavatories.

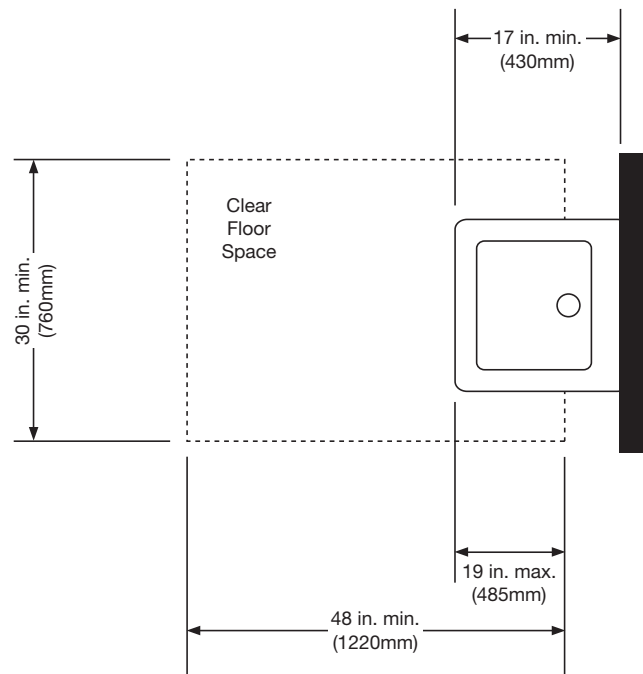



# EVERFORM® SOLID SURFACE FABRICATION GUIDE



## ADA STANDARDS HANDICAPPED ACCESSIBLE LAVATORY TOPS

### Everform® Solid Surface Model L075 or V065 Lavatory bowls with Standard 22 in. (559mm) Deck

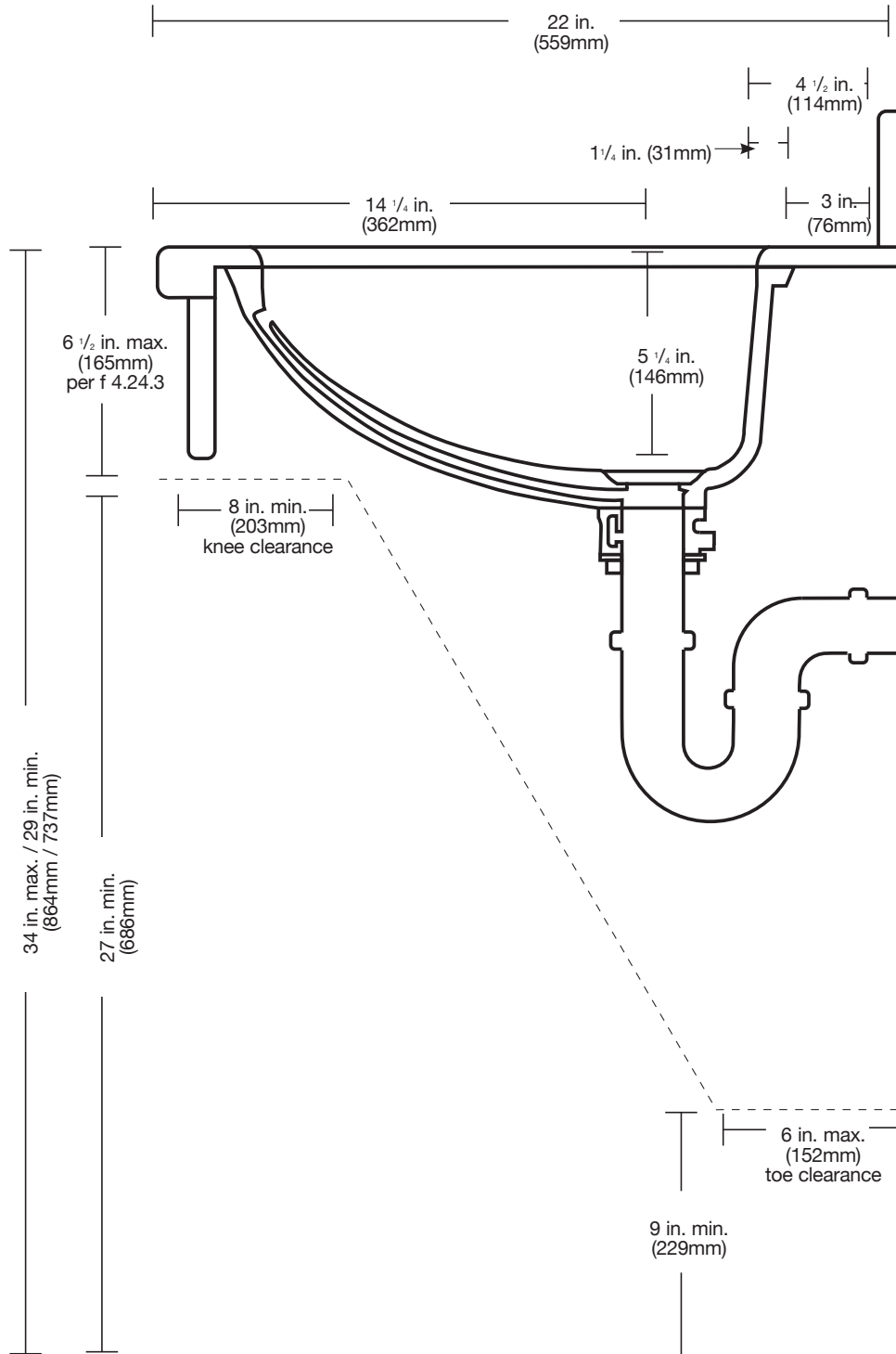

COMMERCIAL

# EVERFORM® SOLID SURFACE FABRICATION GUIDE



## TOILET AND URINAL PARTITIONS SEAMING DIVIDER PANELS

Everform® Solid Surface can be used for toilet partitions and urinal dividers.

- For dividers, doors, side panels, etc. ½ in. (12.5mm) or ¾ in. (20mm) thickness is recommended. Run all seams in horizontal direction for maximum impact strength.
- For pilasters, where more strength is required, ¾ in. (18mm) thickness is recommended.

- If using a Everform® Solid Surface pattern, order sheets finished on both sides or finish the back side to match the surface finish with a random orbital sander.

Partition hardware, fasteners and accessories for standard ADA compliance can be obtained from Jacknob Corp., 290 Oser Ave., Hauppauge, NY 11788. Phone: (888) 231-9333, [www.jacknob.com](http://www.jacknob.com).

### 1. Mirror image rout seam using seam routing fixture (see page 11).

- Use ½ in. (12.5mm), 2 flute carbide straight cutter.

**NOTE:** Run partition seams in horizontal direction for maximum impact strength.

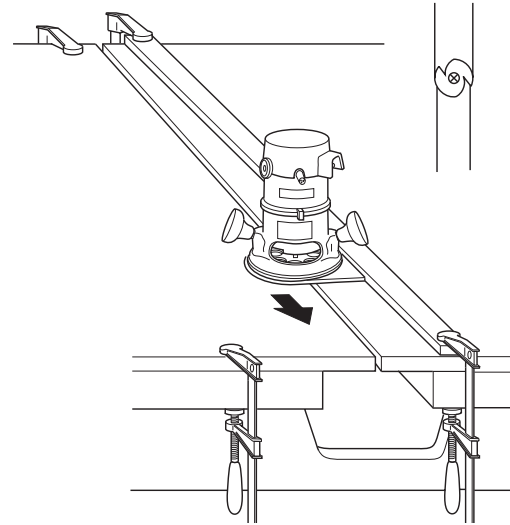

### 2. Check fit by butting together.

- Re-rout if necessary.

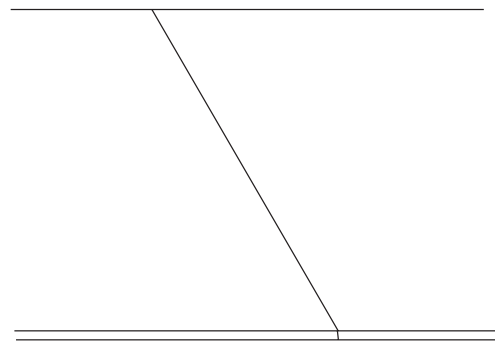

### 3. Clean with denatured alcohol and a clean white rag.

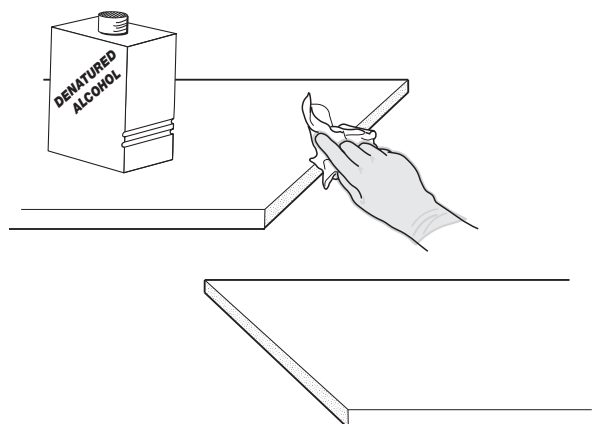

# EVERFORM® SOLID SURFACE FABRICATION GUIDE



## TOILET AND URINAL PARTITIONS SEAMING DIVIDER PANELS

### 4. Tape off supporting work surface with clear packaging tape.

- Center sheets over tape with a 1/8 in. (3mm) gap.

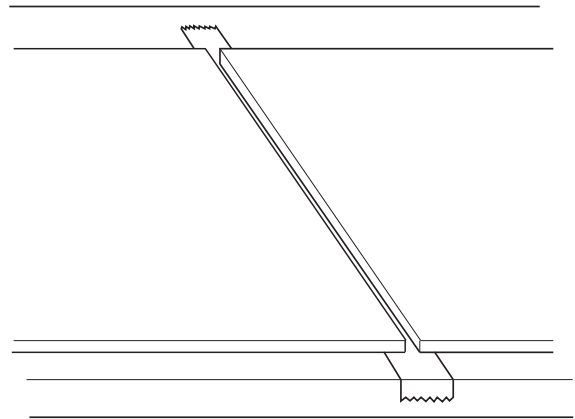

### 5. Sand top surface near the seam line with 120-grit sandpaper to provide a bonding area for hot melt adhered wood blocks.

- Clean and adhere wood blocks with hot melt adhesive.
- The blocks should be approximately 2½ in. x 4 in. x 3/4 in. (63mm x 102mm x 20mm).

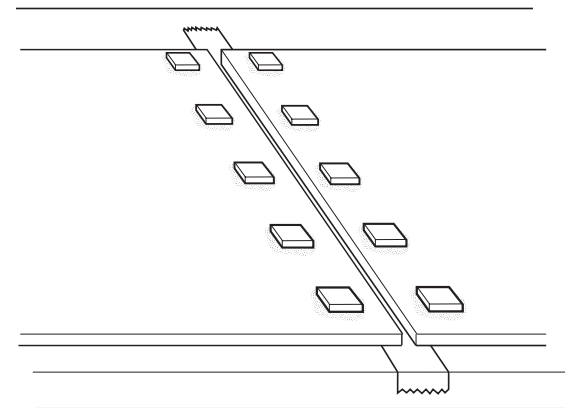

### 6. Fill gap with Everform® Solid Surface seaming adhesive.

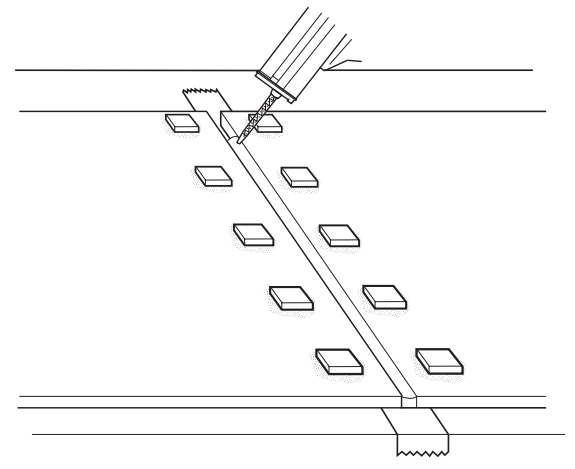

# EVERFORM® SOLID SURFACE FABRICATION GUIDE



## TOILET AND URINAL PARTITIONS SEAMING DIVIDER PANELS

### 7. Push joint together, align surfaces and apply clamping pressure.

- Excess adhesive will squeeze out, do not remove.

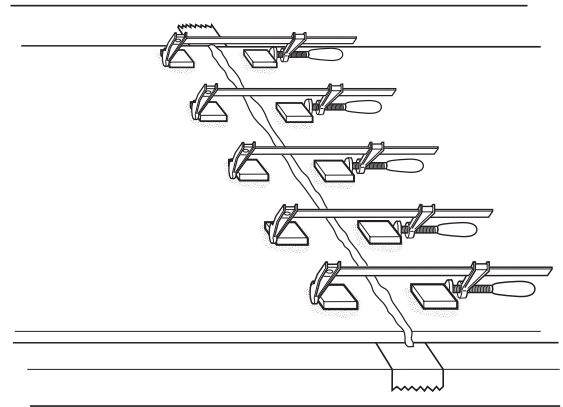

### 8. After adhesive sets, remove clamps and wood blocks.

- To remove wood blocks, first flood blocks with alcohol, wait a few minutes, and then pry off with a wood chisel.
- Protect surface with laminate sample under chisel.

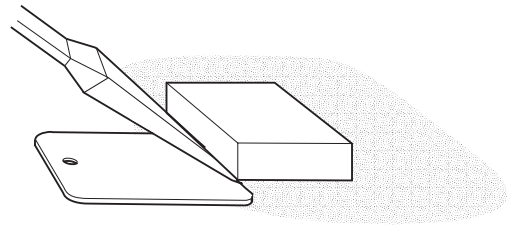

### 9. Remove adhesive bead using a router with ski base and a flat bottom cutter.

- Set bit just above surface.

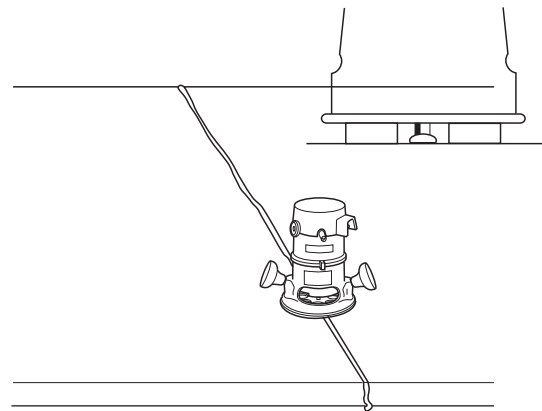

# EVERFORM® SOLID SURFACE FABRICATION GUIDE



## TOILET AND URINAL PARTITIONS SEAMING DIVIDER PANELS

### 10. Use a random-orbital sander with 100 to 120-grit sandpaper to remove remaining adhesive.

- Final finishing is normally done later, after further fabrication steps.

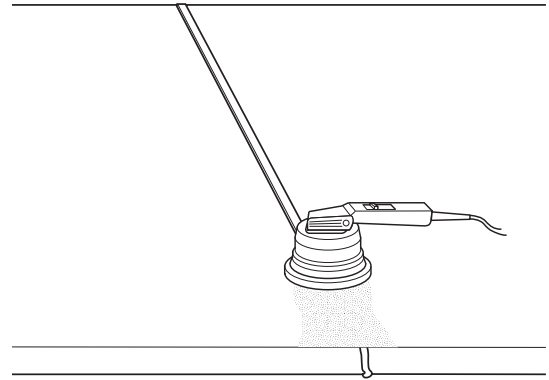

### 11. Flip partition over and sand out seam on other side.

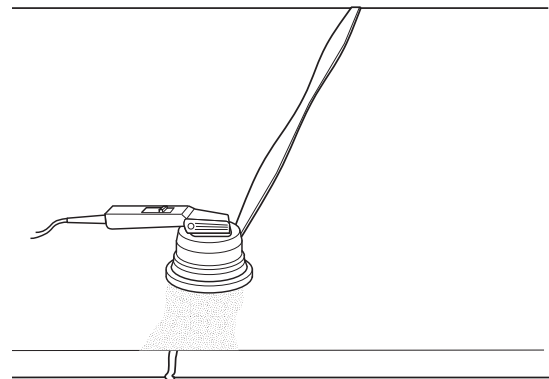

# EVERFORM® SOLID SURFACE FABRICATION GUIDE



## TOILET PARTITIONS

### WALL/PILASTER MOUNTING BRACKET DETAILS

#### 1. Attach wall mounting brackets to wall.

- Mark and drill holes in partition and pilaster  $\frac{1}{16}$  in. (1.5mm) oversized.
- Install partition and attach to pilaster.
- Use of front mounting plates is recommended.
- Three sets of hardware are required for toilet partitions.

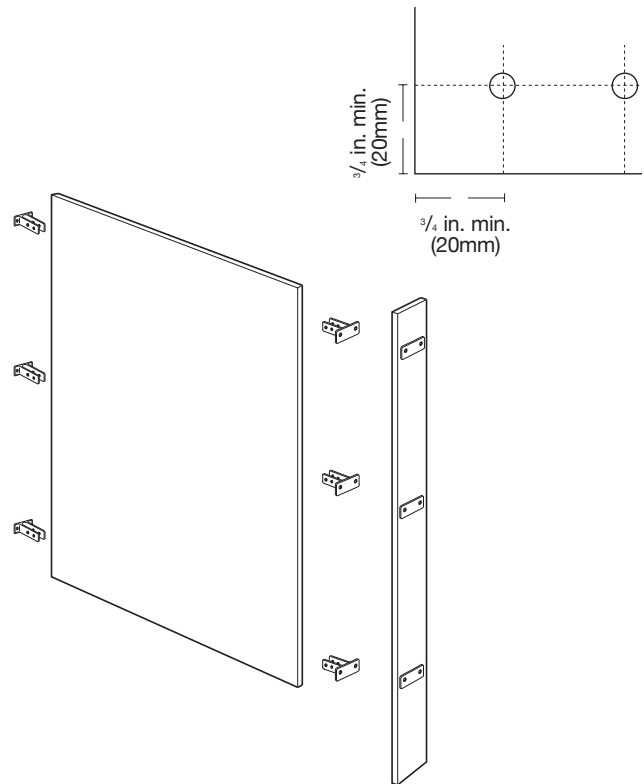

#### 2. Assemble hardware.

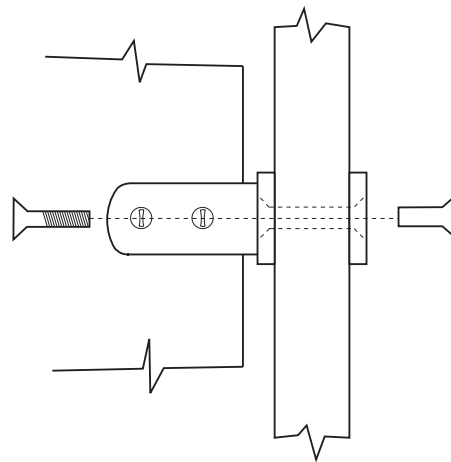

# EVERFORM® SOLID SURFACE FABRICATION GUIDE



## TOILET PARTITIONS DOOR MOUNTING DETAILS

### 1. Use surface mounted hinges with backup plates. Mark and drill holes in partition and pilaster $\frac{1}{16}$ in. (1.5mm) oversized.

- Pilasters must be held firmly with a head rail system and securely fastened to the floor with a pilaster anchor plate.
- For doors up to 30 in. (762mm) wide, use three hinges.
- Larger openings require four hinges.
- Piano hinges can also be used.

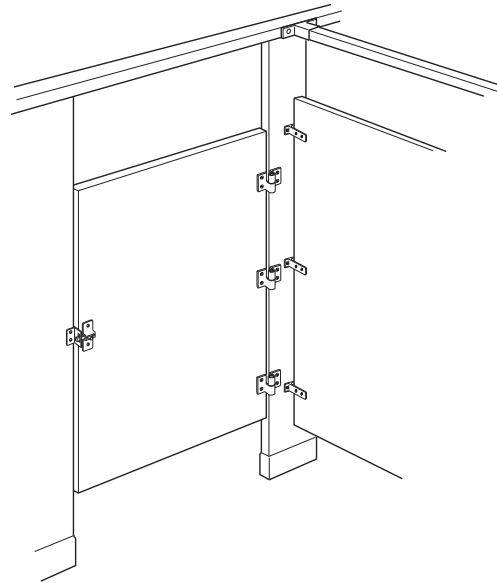

### 2. For standard stalls hang door to swing in

- Use an in-swing keeper latch with a rubber bumper at the strike area.
- For ADA compliant stalls, doors must swing out
- Use an out-swing keeper and slide latch with a rubber bumper at the strike area.
- Use of backup plates for mounting is recommended.

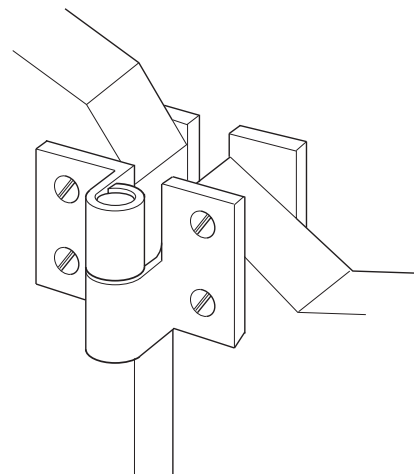
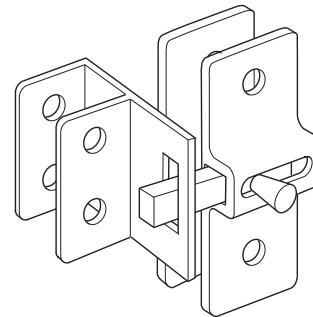

# EVERFORM® SOLID SURFACE FABRICATION GUIDE



## URINAL PARTITIONS MOUNTING DETAILS

### 1. Attach urinal hardware to wall.

- Mark and drill holes for hardware bolts  $\frac{1}{16}$  in. (1.5mm) oversized.

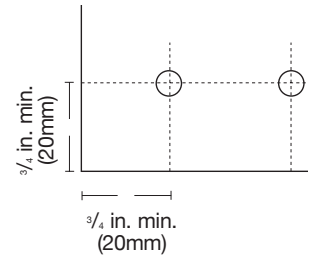
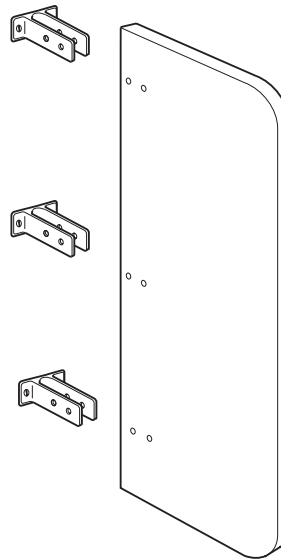

### 2. Install divider.

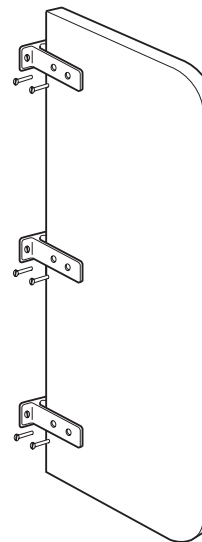



# EVERFORM® SOLID SURFACE FABRICATION GUIDE



## FOOD SERVICE COUNTERTOPS SUPPORT STRUCTURES

### 1. Fixtures must be even and level with no high or low spots that can induce cracking.

- Fasten abutting cabinets together and securely anchor to the wall. If free standing, attach to floor.
- Construct support frame from wood or tubular steel. Do not use particleboard, which can swell and heave when wet.
- Tubular steel should be welded in desired grid configuration. Grind down all welds and high spots.
- Do not use solid substrate for support (i.e. plywood or particleboard).

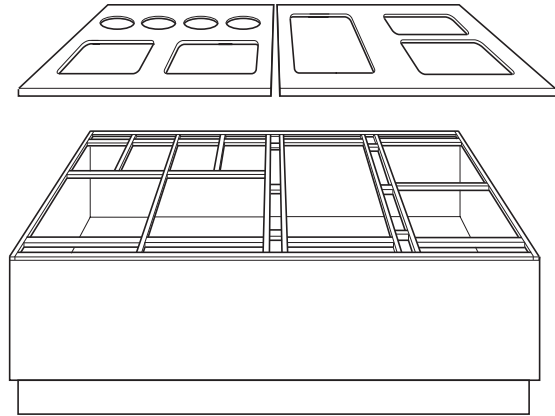

**NOTE:** Commercial food service tops in excess of 24 linear feet will require a flexible joint to accommodate the potential dimensional movement. This can often be coordinated with the flexible joint required between hot and cold sections as illustrated on page 101.

### SUPPORT CRITERIA

If using  $\frac{3}{4}$  in. (20mm) material, provide support every 24 in. (610mm).

- Cantilevers in excess of 12 in. (305mm) require structural support. If using  $\frac{1}{2}$  in. (12.5mm) material, provide support every 18 in. (457mm).
- Cantilevers in excess of 6 in. (152mm) require structural support. Provide perimeter support within 3 in. (76mm) of all cut-outs. Large tops and those that must support heavy equipment will require the use of 1 in. (25mm) or larger tubular steel (i.e. drink dispensers, refrigerated units, etc.). Support framing must be held back  $\frac{1}{8}$  in. (3mm) to  $\frac{1}{4}$  in. (6mm) from drop edges to avoid binding due to frame and/or top movement. Adhere Everform® Solid Surface top to support frame with dabs of silicone applied every 12 in. (305mm) to 18 in. (457mm).
- Do not use a continuous bead.

# EVERFORM® SOLID SURFACE FABRICATION GUIDE



## FOOD SERVICE COUNTERTOPS INSTALLING STEAM-HEATED FOOD WELLS

### 1. Cut opening with router and template.

- Inside corner radius must be a ½ in. (12.5mm) minimum.
- Clearance between cutout edge and steam unit side is to be ¼ in. (3mm) minimum.
- Do not allow seams to run into cutout area. Seams should be 3 in. (76mm) or more from all cutouts.

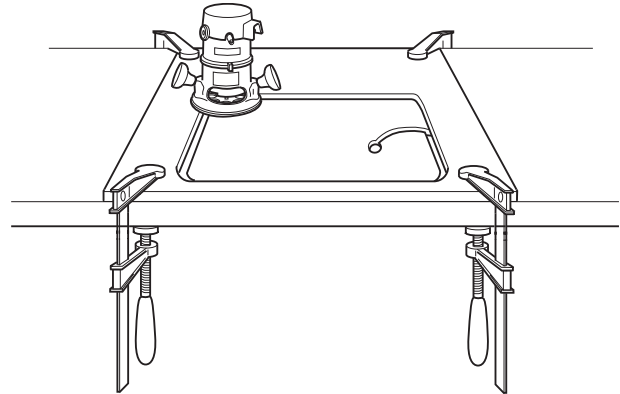

### 2. Reinforce all four corners with corner blocks fabricated from ½ in. or ¾ in. thick Everform® Solid Surface.

- Bond chamfered 3 in. x 3 in. (76mm x 76mm) or larger blocks into underside corners with seaming adhesive.
- Rout excess away with a ball bearing straight cutter.
- Slightly round over all edges by sanding.
- For circular cutouts, a continuous 2-3 in. (50-76mm) ring of material must be bonded to underside with seaming adhesive. Bevel outside perimeter of ring with 45° chamfer.

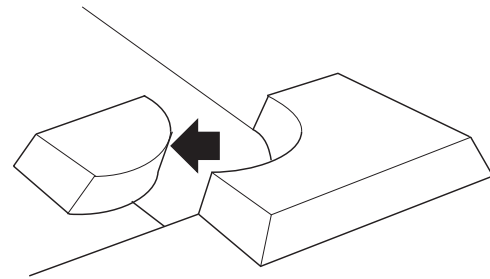

### 3. Apply two layers of heat conductive aluminum tape\* as illustrated.

- Cut off excess with a razor knife and bend under as shown.

**NOTE:** Flange of heat producing unit must contact the two layers of aluminum tape for maximum dissipation.

\*3M® brand 425 or 427 aluminum tape or equivalent.

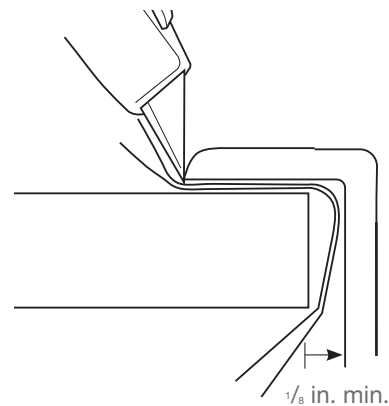

# EVERFORM® SOLID SURFACE FABRICATION GUIDE



## FOOD SERVICE COUNTERTOPS INSTALLING STEAM-HEATED FOOD WELLS

### FOR EVEN GREATER DISSIPATION OF HEAT:

#### 4A. For even greater dissipation of heat, the steam-heated food well can be installed inside a stainless steel collar.

- Reinforce corners and apply aluminum tape to cutout.

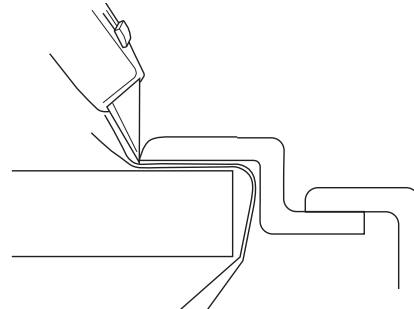

#### 4B. Or set on a “floating” continuous rim fabricated from 1/2 in. (12.5mm) Everform® Solid Surface.

- Radius all inside corners 1/4 in. (6mm), or larger, on both the collar and deck cutouts.
- Reinforce all corners of deck cutout on the underside with beveled 3 in. by 3 in. (76mm x 76mm) minimum corner blocks
- Apply two layers of heat conductive aluminum tape to the collar as illustrated.
- Bond continuous “floating” collar to the deck cutout with an FDR or NSF approved silicone. Use two continuous beads.
- Remove excess silicone.

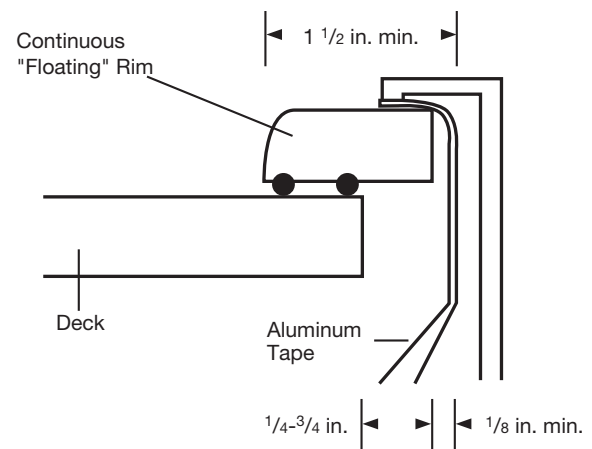

**NOTE:** Steam-heated food wells that are installed with either the stainless steel or solid surface continuous collars can also be used as ice wells, provided that a cool-down or warm-up period of one hour or more is provided before switching operations.

# EVERFORM® SOLID SURFACE FABRICATION GUIDE



## FOOD SERVICE COUNTERTOPS HEAT VENTILATION TECHNIQUES

### 1. Install a louvered vent in the bottom on one side.

- Install a second louvered vent along the top of other side to create convection cooling.

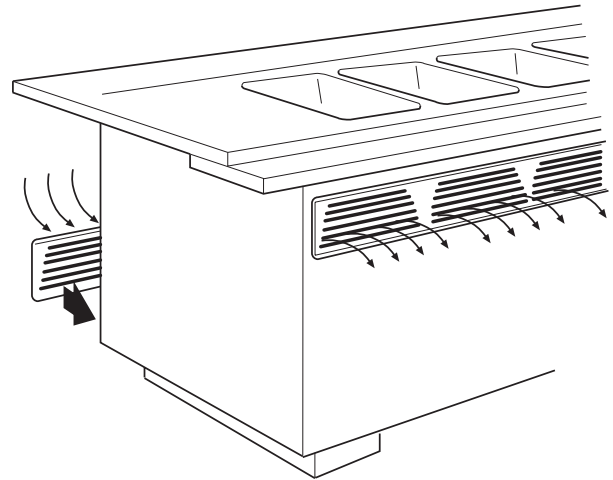

### 2. For forced ventilation, install a fan near the bottom of the cabinet to pull cool air into fixture.

- Provide vents along upper section of fixture.

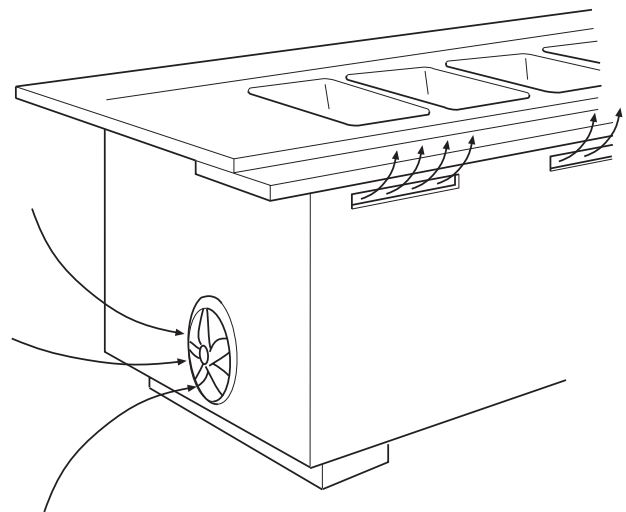

COMMERCIAL

# EVERFORM® SOLID SURFACE FABRICATION GUIDE



## FOOD SERVICE COUNTERTOPS HOT/COLD FOOD SERVICE

**1. Food service tops containing both hot and cold sections must be physically isolated from each other.**

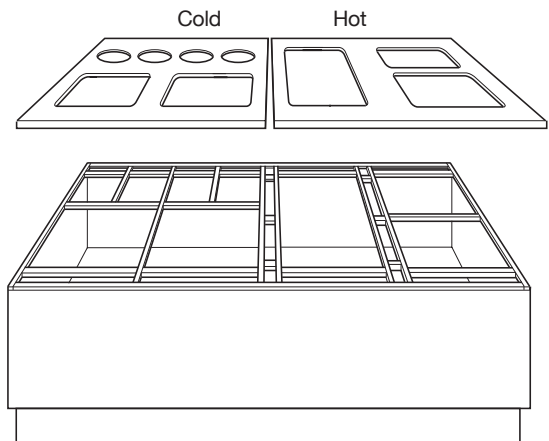

**2. One technique is to gap hot and cold sections about 1/8 in. (3mm) apart. Caulk with an NSF or FDA approved silicone sealant.**

- A slight chamfer on the top side of abutting sections will help keep softer silicone fill below the surface for better performance.

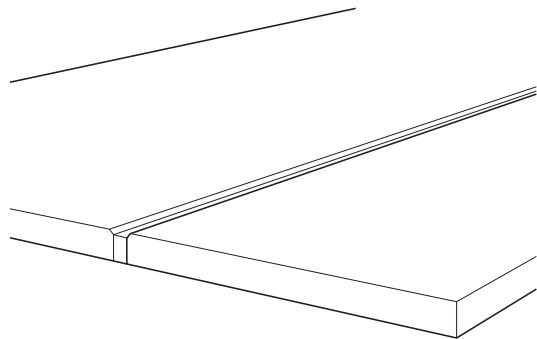

**3. Another technique is to cap the 1/8 in. (3mm) silicone filled gap with a decorative strip made of Everform® Solid Surface or other material (e.g. bronze, stainless steel).**

- Adhere the decorative strip with silicone.

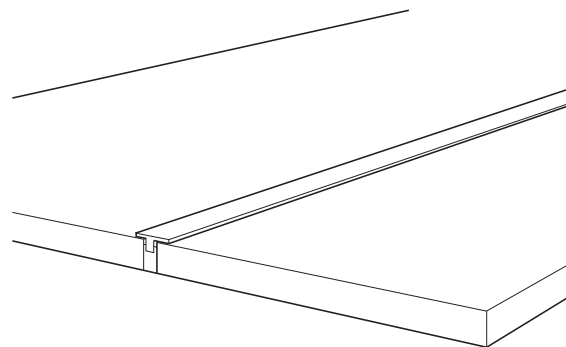

# EVERFORM® SOLID SURFACE FABRICATION GUIDE



## FOOD SERVICE COUNTERTOPS SNEEZE GUARD MOUNTING

**1. Sneeze guard mounting hardware must not restrict the movement of the food service top as it expands or contracts.**

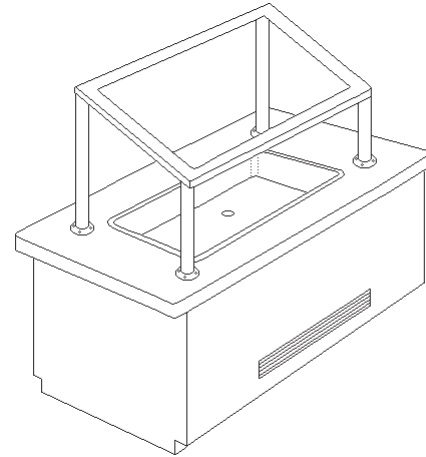

**2. One method of anchoring the sneeze guard mounting flanges is to use metal bushings as illustrated.**

- All holes through the solid surfacing must be  $\frac{1}{8}$ – $\frac{1}{4}$  in. (3–6mm) larger than the bushing diameter.
- Provide adequate structural support under each mounting flange—sneeze guards are heavy.

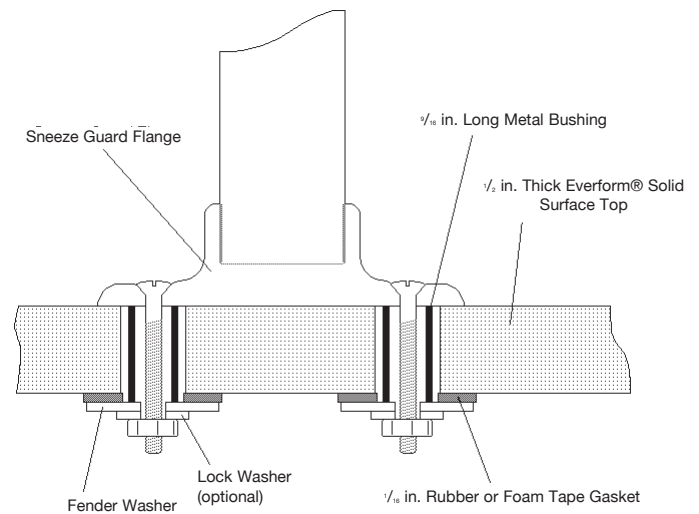

**3. Another method of fastening sneeze guard mounting flanges is to use a load bearing plug to allow the Everform® Solid Surface to move independently of the sub-structure.**

- The hole through the top must be large enough to provide  $\frac{1}{8}$  in. clearance or more for mounting screws.
- Seal gap between flange and deck with an NSF or FDA approved silicone.

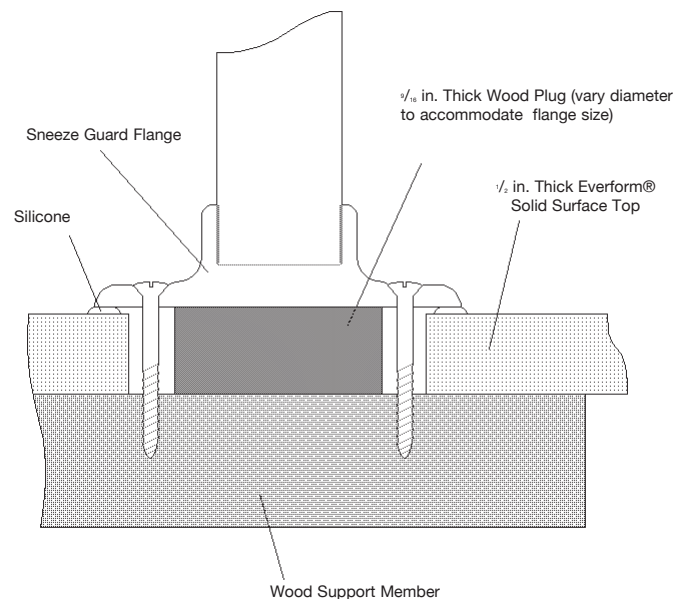

## TABLE TOPS

### 1. Cut a piece of $\frac{3}{4}$ in. (20mm) plywood as a base support.

- Plywood should be cut undersized to allow  $\frac{1}{8}$  in. (3mm) minimum clearance between the plywood and drop edges on all sides.
- Apply continuous beads of silicone around the inner perimeter and at 6-8 in. (153mm-205mm) intervals.
- Press plywood into place.
- Apply weight if necessary.

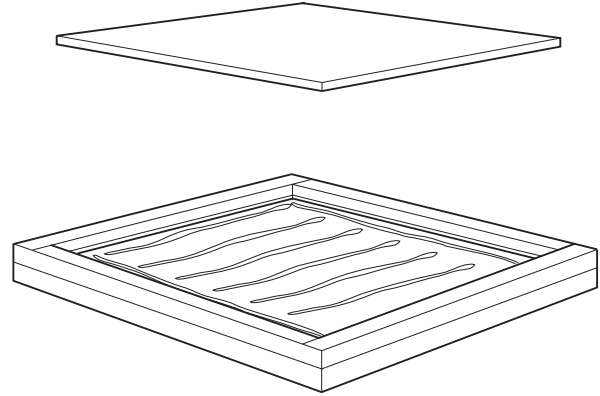

### 2. Fasten table base to underside of table. Make sure screws are proper length.

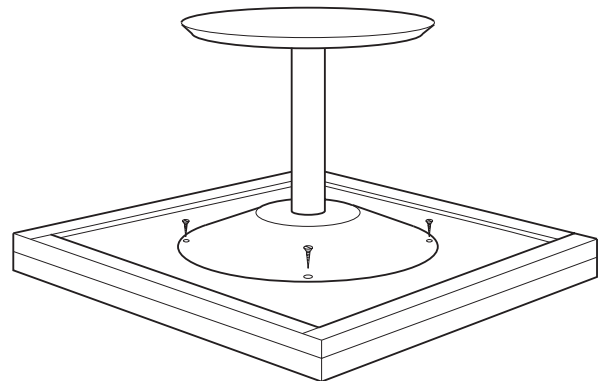

# EVERFORM® SOLID SURFACE FABRICATION GUIDE



## THERMOFORMING

### THERMOFORMING PROCEDURES

To thermoform Everform® Solid Surface, follow the steps in this section.

1. Set up mold clamps and have all tools available.
2. Preheat the oven and maintain a consistent temperature window between 245°F (118°C) and 260°F (127°C). If a higher temperature is used, Everform® Solid Surface becomes more pliable; however, it tears on tight radii. A lower temperature leaves the Everform® Solid Surface too stiff to thermoform.
3. Cut strips of Everform® Solid Surface slightly larger than the finished size requirement.
4. Heat the strips of Everform® Solid Surface until they are uniformly hot.

Size of Material	Time*
Up to 2 square feet ¼ in. (6mm) material	8 minutes
Up to 2 square feet ½ in. (12.5mm) material	12 minutes
2 to 4 square feet ¼ in. (6mm)	10 minutes
2 to 4 square feet ½ in. (12.5mm) material	15 minutes
Over 4 square feet ¼ in. (6mm)	12-15 minutes
Over 4 square feet ½ in. (12.5mm) material	17-20 minutes

\* Approximate time in hot air/convection oven with 15kw duct heater, 1,400CFM blower and 64 cubic feet of cavity space.

5. Remove the Everform® Solid Surface from the oven once it has reached the recommended temperature and has become pliable.

**NOTE:** After removing ½ in. Everform® Solid Surface from the oven, you have a total of 2½ to 3 minutes to work before it becomes too stiff. With ¼ in. Everform® Solid Surface, you have less than 2 minutes to work.

Immediately begin bending the heated Everform® Solid Surface over the appropriate mold, taking 15 to 20 seconds to induce the bend. If a bend is induced too quickly, Everform® Solid Surface will exhibit whitening in the surface.

Clamp the Everform® Solid Surface into place over the appropriate mold. Clamp curved areas first, followed by flat run out areas. The total allowable time for clamping a curved area is 2½ minutes; for flat run out areas the total allowable time is an additional 30 seconds.

6. Release the Everform® Solid Surface from the mold when the temperature reaches 100° F or lower. Depending on the size of the thermoformed piece and the type of mold used, this will take from 15 to 60 minutes.

**NOTE:** Although forced cooling seems to have no detrimental effect, Formica Corporation recommends that Solid Surface be

Formica Group cool gradually on its own.

7. Additional fabrication should occur after the process of heating, forming, clamping over a mold and cooling is complete.
8. Refer to the appropriate chapters in this Fabrication Guide for instructions on cutting, seaming, routing, sanding and performing other fabrication techniques on Everform® Solid Surface.

**NOTE:** Cuts on curved surfaces require special router bases designed specifically for curved surfaces.

### EQUIPMENT

An oven is the recommended heat source for thermoforming Everform® Solid Surface. There are two types of ovens you can use to thermoform Everform® Solid Surface: a hot air/convection oven and an infrared/radiant deck oven. There are advantages and disadvantages to each type of oven. The oven most recommended for thermoforming Everform® Solid Surface is the hot air/convection oven. Instructions for using both types of ovens are provided in this section.

### HOT AIR/CONVECTION OVEN

The hot air/convection oven has the heating element outside the oven cavity, which allows even heat distribution inside the oven. Maintaining even heat distribution permits all Everform® Solid Surface colors and sizes, including large pieces, to be easily accommodated.

Because hot air/convection ovens are not widely available at economical prices, you may want to build one that is customized to your specifications. Inexpensive, yet effective hot air/convection ovens may be shop built using firecode plywood for oven cavities and blowers, duct heaters and controls to provide heat and to control temperature. Before constructing an oven, consult with a local mechanical engineer for plans and directions.

### INFRARED/RADIANT OVEN

Most solid surface fabricators use infrared/radiant deck ovens because they are readily available and inexpensive. However, they are not easy to calibrate and do not hold as even a temperature as a hot air/convection oven. Some manufacturers (e.g. Pinske Edge Systems and SpecialtyTools.com) now offer infrared/radiant ovens with electronic controls that provide much better temperature control and heat distribution.

Infrared/radiant ovens must be individually calibrated according to the thickness, color and specific manufacturer of each piece of solid surface material. Because this type of oven has uneven and erratic temperatures, it is least acceptable for thermoforming Everform® Solid Surface.



# EVERFORM® SOLID SURFACE FABRICATION GUIDE



## THERMOFORMING

### MOLDS

Heated Everform® Solid Surface should be shaped over a mold. The best type of mold to use depends on the design of the piece. To determine the mold that is the best for your design, refer to the chart below.

TYPE OF MOLD	EASE OF USE	EASE OF CONSTRUCTION	SUITABILITY FOR TIGHT RADII	COOLING SPEED	SUITABILITY FOR LARGE SURFACES
Radial Clamp	Very Good	Excellent	Poor	Fast	Excellent
Web Clamp	Very Good	Excellent	Poor	Fast	Excellent
Male/Female Comb	Very Good	Poor	Very Good	Slow	Excellent
Hinged	Good	Poor	Very Good	Slow	Excellent
Sweep Arm	Excellent	Poor	Excellent	Fast	Good

For the best results, construct the molds according to these guidelines.

- Use frame construction to provide for adequate heat dissipation.
- Use ¾ in. cabinet grade plywood stringers placed three inches on center with a minimum section of six inches and sheathed with ¼ in. hardboard. This maintains the design integrity of the mold at 22 pounds per square inch.

# EVERFORM® SOLID SURFACE FABRICATION GUIDE



## THERMOFORMING

Following are descriptions of five types of molds that can be used to bend heated Everform® Solid Surface

### SIMPLE MOLD

#### 1. Radial Clamp Mold

- This is a simple male mold with radial clamping.

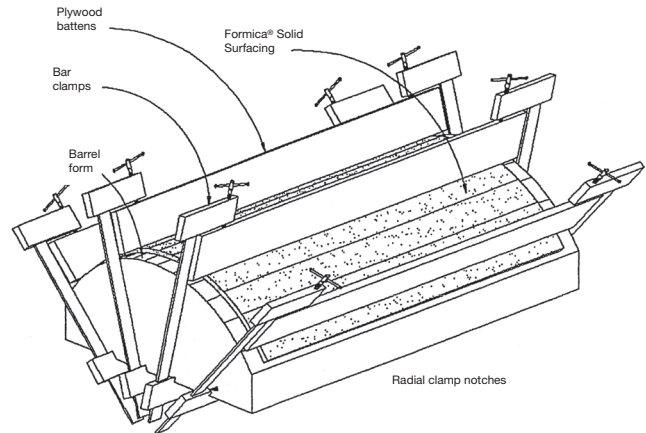

#### 2. Web Clamp Mold

- This is a simple male mold with web clamping. A protective slip-sheet must be used to prevent indentations in the Everform® Solid Surface.

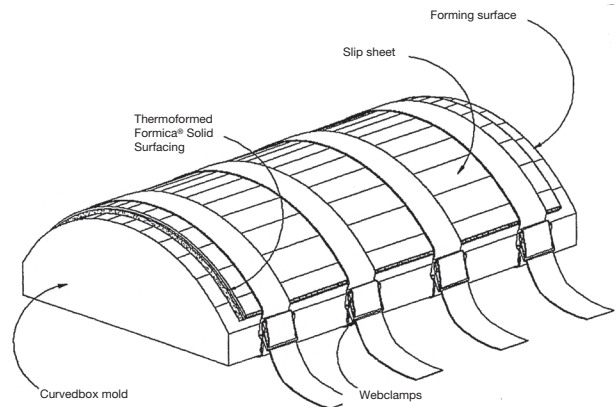

### COMPLEX MOLDS

#### 3. Combination Two-Sided Mold

- A male to female combination mold is generally appropriate for forming tighter radii on larger pieces, such as columns.

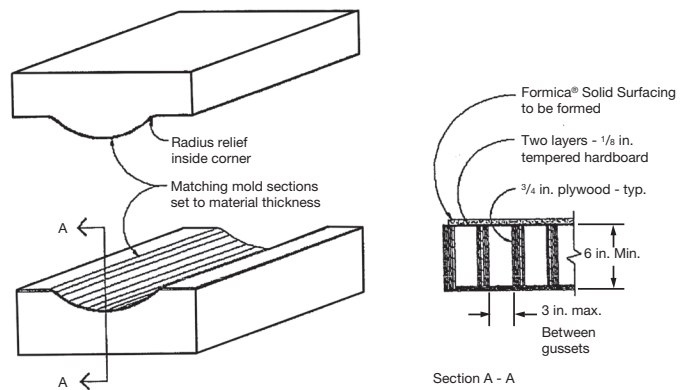

## THERMOFORMING

### 4. Hinged Mold Design

- A hinged or articulated female mold with male mold is used when the tightest possible radii are attempted over long lengths perpendicular to the axis of the curve.

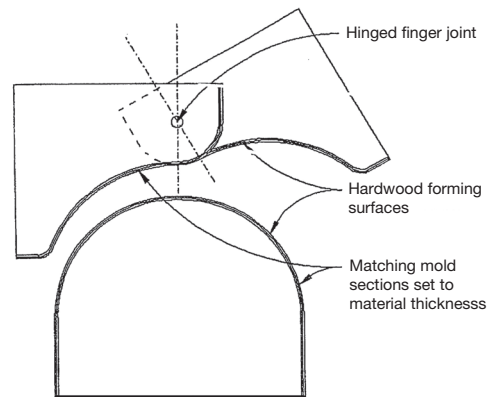

### 5. Sweep Arm Mold

- A sweep arm mold is useful when forming narrow strips of Everform® Solid Surface.

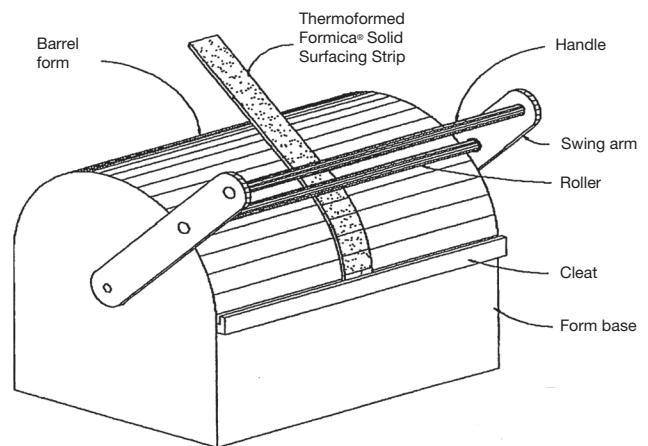

# EVERFORM® SOLID SURFACE FABRICATION GUIDE



## FINISHING VISUAL INDEX

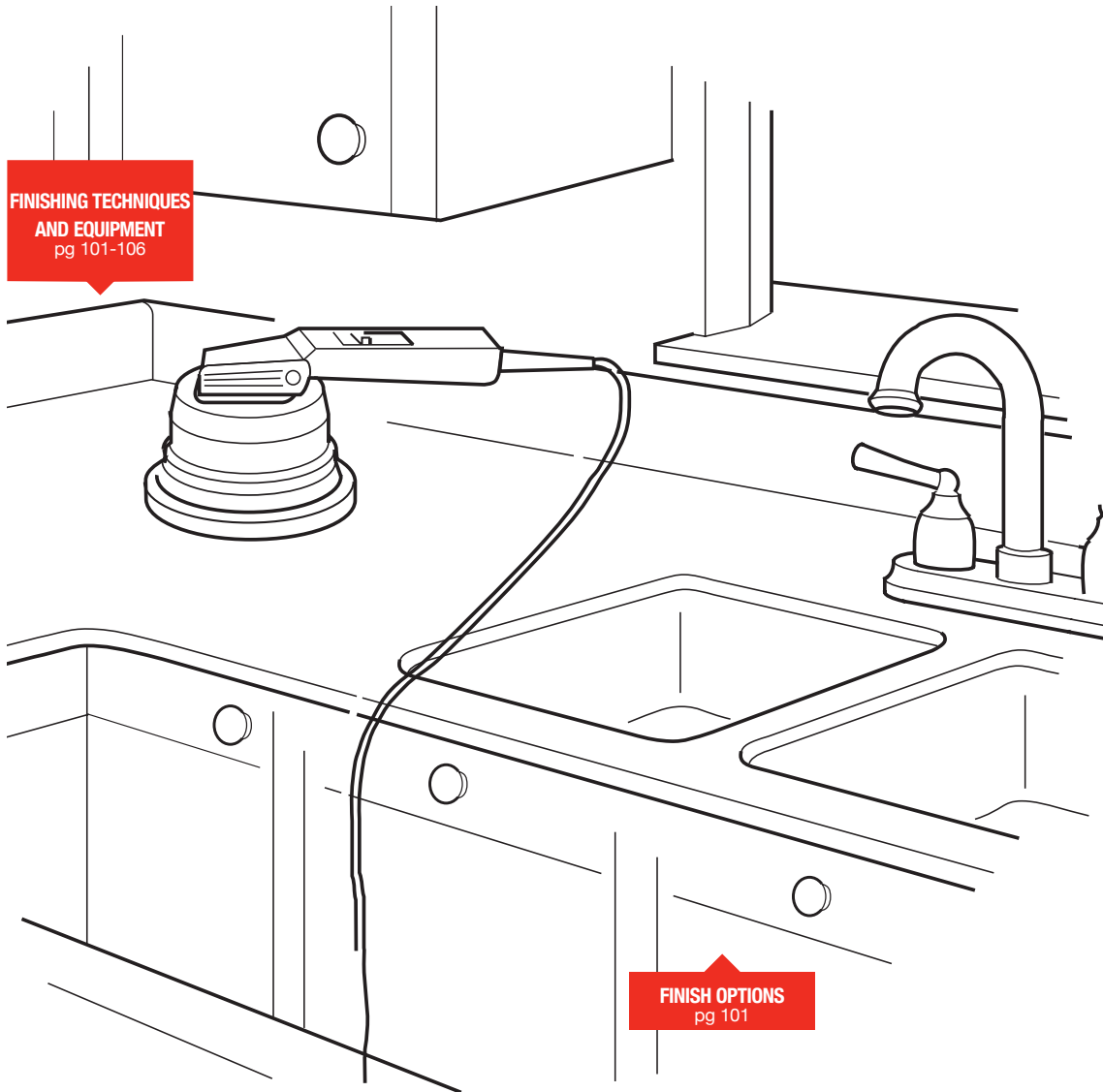

FINISHING

# EVERFORM® SOLID SURFACE FABRICATION GUIDE



## FINISHING

### FINISHING EVERFORM® SOLID SURFACE

Everform® Solid Surface sheets and molded shapes are finished to a satin finish in the factory but fabrication and installation operations, as well as customer selection of other finishes, make it necessary for the fabricator and/or installer to adjust the final finish.

There are three basic finishes that are used. Each of these have certain advantages and disadvantages that should be seriously considered for each application. The properties of these finishes are described below:

FINISH	PROPERTIES	HOW MAINTAINED
<b>MATTE</b>	A soft, low gloss finish that “hides” minor scratches, etc.  Best used on light colors.	Soap and water, abrasive cleaners, Scotch-Brite® pad #7447 or equivalent.
<b>SATIN</b>	A soft, semi-gloss finish that enhances visual appearance of dark solids and patterns.  Slightly more stain resistant than matte finish.	Soap and water, abrasive cleaners, Scotch-Brite® pad #7448 or equivalent.
<b>POLISHED</b>	A high gloss finish that enhances the visual depth and character of dark solids and patterns.  Most stain resistance due to surface characteristics.  Most difficult to maintain; minor scratches and mars are more noticeable.  Resanding and polishing require special skills and equipment.	Soap and water, non-abrasive cleaners on a soft, non-abrasive cloth.

## FINISHING

### SANDING ABRASIVES

The abrasive mineral of choice for finishing solid surfacing material is aluminum oxide. It is available in various sizes from coarse to extremely fine in either the P-graded grit or micron forms. The following is a relative comparison of these two grading systems.

P-GRADE	MICRON
P120 grit	100 micron
P150 grit	N/A
P180 grit	80 micron
P220 grit	60 micron
P320 grit	40 micron
P400 grit	30 micron
P600 grit	15 micron

Both the P-graded grit and micron systems have a tight control of the size distribution. This results in fewer deep scratches and a better finish in fewer steps. The use of standard grit sized abrasives is not recommended due to the large distribution range for each grit size, which can result in a poorer finish quality and more sanding steps.

Aluminum oxide abrasives are available in various forms, which have their own specific purpose and utility. The basic forms used to finish solid surfacing material are as follows:

#### Sanding discs

Available with heavy weight paper or film backing in various diameters and hole configurations to fit various random orbital sanders. Can be obtained in both wet or dry sanding versions with hook-and-loop backs.

Micron	3M® 268L or 366L film backed discs in 100, 80, 60, 40, 30 and 15 micron sizes. 3M® Trizact® film* in 268XA-A35, -A10, -A5 micron sizes.
P-Graded Grit	3M® 255L film backed discs or Mirka® Q-Silver in P-120, -150, -180, -220, -320, -400, -600 grit sizes.

\*The Trizact® abrasives have a unique uniform aluminum oxide structure, which causes it to last much longer than conventional forms of aluminum oxide abrasive particles. This results in a more uniform finish from start to finish, since the abrasive is not changing as it wears.

# EVERFORM® SOLID SURFACE FABRICATION GUIDE



## FINISHING

### NON-WOVEN NYLON ABRASIVE PADS:

Used for final finishing to matte or satin finish, maintenance, etc. Generally used in two grades:

Maroon (very fine) for matte finish	3M® Scotch-brite® #7447 Mirka® Mirlon #447
Gray (ultra fine) for satin finish	3M® Scotch-brite® #7448 Mirka® Mirlon #448

### MIRKA® ABRALON FOAM BACKED PADS:

An alternate to the non-woven nylon pads for final finishing to a matte or satin finish. The foam backing results in more even pressure, which helps eliminate certain finishing problems. Can be used wet or dry with hook-and-loop equipped sander bases. Generally used in the following sequence to obtain a matte or satin finish after first sanding to a P220 grit or 30 micron level.

**ABRALON 8A-241-180:** Preliminary step (evens out finish on high and low pressure areas)

**ABRALON 8A-241-360:** Gives matte finish

**ABRALON 8A-241-500:** Gives satin finish

**ABRALON 8A-241-1000:** Gives a satin-plus finish

Abralon pads can also be used to obtain higher gloss levels without the use of buffing and polishing compounds. This can be accomplished by first sanding to a P320 grit or 30 micron level and then wet finishing with the Abralon pads in the following sequence.

Abralon 8A-241-360  
Abralon 8A-241-500  
Abralon 8A-241-1000  
Abralon 8A-241-2000  
Abralon 8A-241-4000

### LIQUID POLISHING COMPOUNDS:

Used to obtain polished finishes after pre-finishing to a P600 grit or 15 micron level. Must be used with a power buffer.

**FIRST BUFFING STEP:** 3M Finesse-it® Compounding Material  
#051144-77340

**FINAL BUFFING STEP:** 3M Finesse-it® Finishing Material  
#051144-81235

### MAJOR ABRASIVE SUPPLIERS:

#### 3M ABRASIVE SYSTEMS DIVISION

3M Center, Building 223-6N-01  
St. Paul MN 55144-1000  
888-364-3577  
<http://www.mmm.com/abrasives>

#### MIRKA ABRASIVES INC

7950 Bavaria Road  
Twinsburg, OH 44087  
800-843-3904  
<http://www.mirka-usa.com>

# EVERFORM® SOLID SURFACE FABRICATION GUIDE



## FINISHING DARK COLORS

Formica Corporation has developed a fabrication technique that will help fabricators improve the appearance of drop edge build-up seams. This fabrication technique will work for all Everform® Solid Surface designs, but it is critical when working with Dark Colors.

This technique has been developed to insure the highest quality finished product by minimizing visible (white) seams in drop edge build-up assemblies. During final finishing, in our manufacturing facility, the back of the sheet is sanded using 100-grit sandpaper with a wide belt sander. This process enables us to maintain thickness tolerances and ensures a consistent flat back of the sheet. The back sanding, however, creates whiteness on the back of the sheet that, if not removed, could create a visible seam in drop edge build-ups.

### TO ACHIEVE THE BEST POSSIBLE EDGE APPEARANCE WITH DARK COLORS:

- Sand the back side of the countertop deck (in the drop edge area) and sand the face and back of each edge strip with 120-grit ( 100 micron) sandpaper using a random orbital sander.
- Sand until the white linear lines have been removed from the back of the sheet/strip and the face has been roughed up enough to insure proper bonding.
- Always glue the face of the material to the back of the next piece in the drop edge assembly.
- Use recommended color matched adhesive.

## FINISHING DARK COLORS

Formica Corporation fabrication techniques that will help fabricators improve the appearance of the finish in dark colors. These fabrication techniques will work for all Everform® Solid Surface designs, but it is critical when working with Dark Colors.

Everform® Solid Surface sheets, InDepth Surfacing and molded shapes are finished to a satin finish in the factory but fabrication and installation operations, as well as customer selection of other finishes, make it necessary for the fabricator and/or installer to adjust the final finish.

The abrasive mineral of choice for finishing solid surfacing material is aluminum oxide. It is available in various sizes from coarse to extremely fine in either the P-graded grit or micron forms. We recommend using the Micron system for sanding. Below is a chart of the standard grits that are available. 100 micron would be the coarsest and 15 would be the finest on this chart.

### MICRON SYSTEM

100 micron

80 micron

60 micron

40 micron

30 micron

15 micron

### NON-WOVEN NYLON ABRASIVE PADS

Used for final finishing to matte or satin finish, maintenance, etc. Generally used in two grades:

**Maroon:** (very fine) for matte finish 3M Scotch-Brite #7447 Mirka® Mirlon #447

**Gray:** (ultra fine) for satin finish 3M Scotch-Brite #7448 Mirka® Mirlon #448

When sanding Dark Colors, it is important to not skip the progression of grit or micron. For example it would be incorrect to sand with 100 micron and skip to 60 micron when sanding Dark Colors. The correct step would be 100 micron, 80 micron, 60 micron.

Always clean thoroughly between sanding steps. Particles from the abrasive pads could be left on the surface, so when the next step of sanding occurs, larger particles will cause “swirls” and create a poor finish.

In most cases, solid surface countertops should be installed with a “matte” finish. This is achieved by sanding to 60 micron and then a maroon abrasive pad 3M Scotch-Brite #7447. To enrich the color of the Dark Colors, it may require extra steps of sanding. A “satin” finish may be required. To achieve this sand with 100 micron, 80 micron, 60 micron, 30 micron and a gray abrasive pad 3M Scotch-Brite #7448. Sanding wet with the #7448 will create a more uniform finish. The use of a 500 grit Abralon pad made by Mirka also helps bring the color out of a dark color.

There are also many quality manufactures of large profile sanding equipment that will increase your productivity and help you sand to a high quality finish. Gem Industries [www.gemindustries.com](http://www.gemindustries.com) and Pinske [www.pinske-edge.com](http://www.pinske-edge.com) are just a couple.

### FINISHING EVERFORM® SOLID SURFACE

Everform® Solid Surface sheets and molded shapes are finished to a satin finish in the factory but fabrication and installation operations, as well as customer selection of other finishes, make it necessary for the fabricator and/or installer to adjust the final finish.

There are three basic finishes that are used. Each of these have certain advantages and disadvantages which should be seriously considered for each application. The properties of these finishes are described below:

MATTE		SATIN		DARK COLORS	POLISHED
P-grade	Micron	P-grade	Micron	Micron	Micron
120	100	120	100	100	100
180	80	180	80	80	80
220	60	220	60	60	60
320	30	320	30	30	40
3M® Scotch-Brite Maroon #7447		3M® Scotch-Brite Gray #7448		3M® Scotch-Brite Gray #7448 – Wet	30
				Mirka® Abralon 8A-241-500 – Wet	15
					9
					3M® Finesse-it #051144 -77340
					3M® Finesse-it #051144-81235



# EVERFORM® SOLID SURFACE FABRICATION GUIDE



## FINISHING

### BASIC SANDING TECHNIQUE

1. First, sand in one direction. Overlap about one-third with each pass.

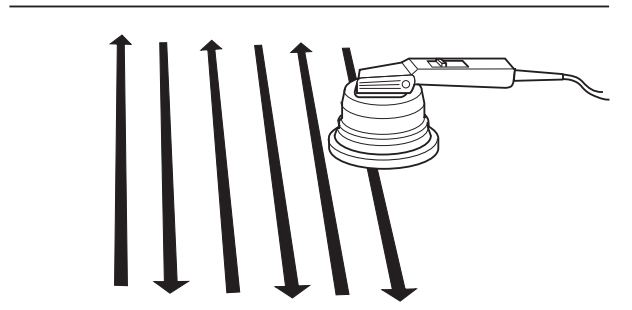

2. Next, sand in a direction that is perpendicular to the first step. Overlap about one-third with each pass.

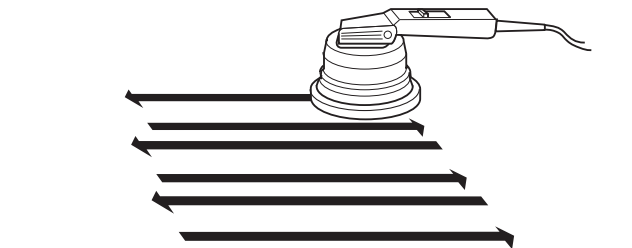

3. Next, sand at a diagonal as shown. Overlap about one-third with each pass.

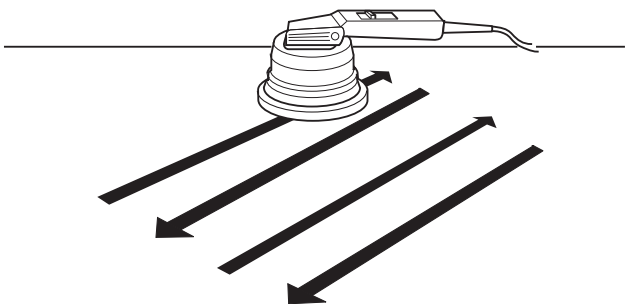

4. Finally, sand in opposite diagonal direction as shown. Overlap about one-third with each pass.

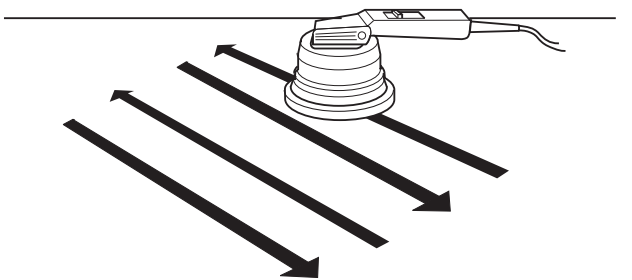

# EVERFORM® SOLID SURFACE FABRICATION GUIDE



## FINISHING BASIC SANDING TECHNIQUE

### 5. Remove paper from sander and hand sand the edges.

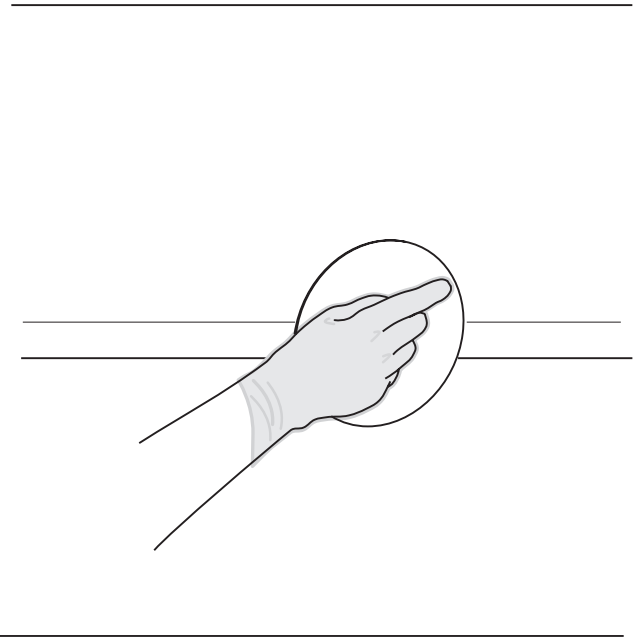

### 6. Brush off and wipe clean with a damp cloth.

- Repeat steps 1-5 with each abrasive size until desired finish is obtained.

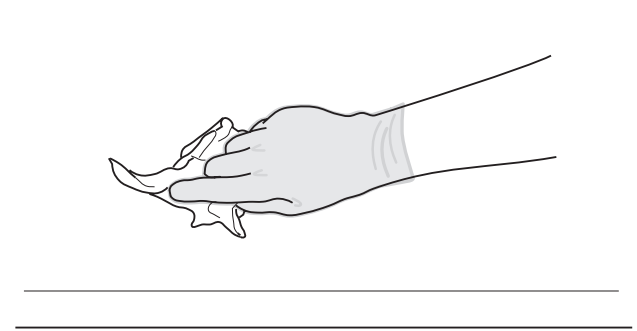

# EVERFORM® SOLID SURFACE FABRICATION GUIDE



## ADHESIVES

**WARNING:** For health hazard information, refer to page 3 and request the material safety data sheet (MSDS) for Everform® Solid Surface adhesives and activator.

CHARACTERISTIC	9 OZ. BULK SEAMING CARTRIDGE	CHARACTERISTIC	9 OZ. BULK SEAMING CARTRIDGE
<b>APPLICATION COVERAGE</b>	50 ft. (15.2m) of seam or drop edge.	<b>STORAGE</b>	Store vertically in original, sealed packaging with nozzle end up, away from direct sunlight and below 75°F (21°C). To prolong shelf life, store in a dark place below 55°F (13°C).
<b>APPLICATION METHOD</b>	Special gun and mixing nozzles (mixes when dispensed).		
<b>MIXING</b>	Mixes only amount needed. No measurement required.	<b>BLEEDING OF SEAMING CARTRIDGE</b>	<p>To ensure the proper mixing of adhesive and catalyst, the seam cartridge must be bled prior to use.</p> <p>After the cartridge has been inserted into the gun, unscrew the plastic collar and remove the gray pin.</p> <p>Squeeze the seaming gun handle gently without a nozzle until both the adhesive and catalyst appear.</p> <p>Attach the nozzle and squeeze out the initial adhesive before using. A couple squeezes of the gun handle will do.</p> <p>The procedure must be completed each time a new nozzle is attached to the cartridge.</p>
<b>COMPOSITION</b>	Acrylic resin, pigment and catalyst.		
<b>CURING TIME</b>	45 mins. after mixing at 70°F (21°C).		
<b>WORKING TIME</b>	12-15 mins. at 70°F (21°C).		
<b>SEAM STRENGTH</b>	Strong.		
<b>SHELF LIFE</b>	Expires as per date on label.		
<b>USES</b>	For bonding Everform® Solid Surface to itself where rapid cure is required. Ideal for both shop or on-site use.		
<b>SEAM QUALITY</b>	Excellent with proper seam preparation.		

# EVERFORM® SOLID SURFACE FABRICATION GUIDE



## TOOLS

### BASIC TOOL LIST

	TOOLS	NUMBER NEEDED	BASIC USE
SAWS	Table saw, 10 in. (254mm) or larger with a carbide, triple chip blade and a 6 in. (152mm) blade stiffener.	ONE	For cutting edges, backsplashes, etc.
	7¼ in. (184mm) wormdrive Skilsaw® model HD77M hand saw with carbide blade.	ONE	For rough cutting of sheets.
	Bosch® #1581VS or DVS saber saw with a 10-14 tooth bimetal, up-stroke cutting blade.	ONE	For rough cutting of curved sections.
ROUTERS	Porter-Cable® #7518 Speedmatic® or Bosch® #1611 3¼ HP, ½ in. collet.	ONE	For seaming, routing edges, sinks, etc.
	Porter-Cable® #690, 1¼ HP or Bosch® #1604, 1½ HP.	ONE OR TWO	For profile and light routing.
	Porter-Cable® #310 trimmer set up with a ski base and ¾ in. (20mm) mortise bit.	ONE	For routing off excess seam adhesive.
BELT SANDER		ONE	For dressing down backside of shop seams, removing large amounts of material, sanding to a scribe line, etc.
RANDOM ORBITAL SANDERS	Electric Porter-Cable® #7335, 5 in. (127mm), hook-and-loop base, variable speed.	ONE	For sanding out sink and bowl edges.
	Electric Bosch® #1370 DEVS with RS6020 6 in. (152mm) hook-and-loop pad or Fein 6 in. (152mm) hook-and-loop sander.	ONE	For sanding down seams and flat surfaces in shop or on-site.*
	Pneumatic (air) Dynabrade Dynorbital® #56007/56012, 5 in./6in. (127mm/152mm) or hook-and-loop (available with self-contained dust collection).	ONE	For sanding down seams, flat surfaces, bowl edges (5 in. model). Best for handling on edges due to low profile.

\*These sanders, if equipped with a vacuum system, can greatly reduce the amount of air-borne dust generated during shop and on-site finishing operations.

# EVERFORM® SOLID SURFACE FABRICATION GUIDE



## TOOLS

### BASIC TOOL LIST

	TOOLS	NUMBER NEEDED	BASIC USE
CLAMPS	Pony® #3202, 2 in. (50mm) spring clamps.	<b>TEN DOZEN, MIN.</b>	For clamping edges.
	Adjustable clamps with 12 in. (305mm) opening, 4-6 in. (102mm-152mm) throat.	<b>SIX</b>	For clamping kitchen sinks, straight edges, templates, backsplashes, etc.
	Adjustable clamps with 18 in. (457mm) opening, 3 in. (76mm) max. throat.	<b>TWO</b>	For clamping through drain while bonding undermount kitchen sinks.
	Vice-Grip Model 18R or 18DR welder's clamps	<b>SIX (OPTIONAL)</b>	For rapid clamping of undermount kitchen sinks.
BASIC CARBIDE ROUTER BITS	Velepec #10-285, 2 flute, ½ in. (12.5mm) shank, 1 in. (25mm) face.	<b>TWO</b>	For routing seams in ½-¾ in. (12mm-20mm) sheets.
	Velepec #10-320, 2 flute, ½ in. (12.5mm) shank, 2 in. (50mm) face.	<b>TWO</b>	For routing seams in tops with 1-½ in. (4cm) front edges, routing edges after gluing, etc.
	Velepec #10-290, 1 flute, ½ in. (12.5mm) shank, 1 ¼ in. (31mm) face, ½ in. (12.5mm) wide.	<b>ONE</b>	For routing out drop-in range cutouts, etc. requiring ¼ in. (6mm) radius corners.
	Velepec #14-150, 2 flute, ½ in. (12.5mm) shank, 1 ½ in. (38mm) face, bearing guide.	<b>ONE</b>	For routing out reinforcing corner blocks in drop-in range cutouts, etc.
	Velepec #14-160, 2 flute, ½ in. (12.5mm) shank, 2 in. (50mm) face, bearing guide.	<b>ONE</b>	For template cutting of inside and outside corners, etc.
	Formica® Brand KSST stagger tooth cutter with tapered plastic bearings. (Formica® part #S6201003)	<b>ONE</b>	For routing out center of sinks and lavatory bowls.
	Formica® Brand LBBN bullnose cutter (Formica® part #S6201005)	<b>ONE</b>	For routing out a bullnose overhang above undermount kitchen sinks and lavatory bowls.
	Velepec #30-165, ½ in. (12.5mm) shank, bowl bit	<b>ONE</b>	For routing BK420 sinks.

# EVERFORM® SOLID SURFACE FABRICATION GUIDE



## TOOLS

### BASIC TOOL LIST

	TOOLS	NUMBER NEEDED	BASIC USE
BASIC CARBIDE ROUTER BITS	Formica® Brand KSRO roundover cutter with a tapered bearing. (Formica® part #S6201001)	<b>ONE</b>	For routing roundover profile on kitchen sinks and lavatory bowls.
	Formica® Brand VTUMN-RO roundover cutter for Model V065 and V075 bowls. (Formica® part #S6201020)	<b>ONE</b>	Specific profile cutter for use with Model V065 and V075 lavatory bowls.
	Velepec file #75719 custom 3/8 in. (1mm) radius cove bit.	<b>ONE (OPTIONAL)</b>	For routing cove backsplashes with a router table set-up.
	Amana Tool® #45986 1/4 in. (6mm) radius cove bit.	<b>ONE (OPTIONAL)</b>	For routing cove backsplashes with a router table set-up.
	Assorted selection of roundover profile carbide cutters.	<b>AS NEEDED</b>	For edge profiles.
	Assorted selection of ogee and reverse ogee carbide cutters.	<b>AS NEEDED</b>	For edge profiles.
	Carbide 45° chamfer bit with bearing.	<b>AS NEEDED</b>	For edge profiles, chamfering reinforcing strips, corner reinforcement blocks, etc.
MISC. TOOLS	Electric or battery-operated hand drill with assorted drill bits, hole saws, etc.	<b>ONE</b>	For various drilling operations (holes for faucets, etc.)
	3M Polygun® TC with Jet-melt™ 3738-Q adhesive sticks.	<b>ONE</b>	For temporary gluing of glue blocks, etc. during fabrication operations.
	Stationary belt or disc sander.	<b>ONE</b>	For squaring drop edge butt joints.

# EVERFORM® SOLID SURFACE FABRICATION GUIDE



## INDEX

Abrasives	102-103	Lavatory Tops	
ADA Standards	80-81	Aprons	79
Adhesives	107	Between End Walls	75-76
Backsplashes		Support	77-78
Coved	43-48	Overhang Support	34-38
Flexible Joints, Square	39-40	Polishing	101-103
Rigid Joints, Square	41-42	Safety Information	
Tiled	49-51	Activators	3
Bath Surrounds	55-56	Adhesives	3
Color Matching	6	Sheets	3
Countertops		Seam Placement	7-10
Cook Tops	30-31	Seam Preparation	
Edging	19-24	Field Seams	15-18
Heat Protection	27	Shop Seams	11-14
Overhang Support	31	Shower Surrounds	57
Seaming Methods	9-16	Sink Mounting	26-29, 53-54
Seam Placement	6-8	Support	32-38
Seam Reinforcement	12	Table Tops	95
Support	2-35	Templating	6
Cutting Sheets	4	Thermoforming	96-99
Edge Assemblies	19-24	Toilet Partitions	86-87
Finishing	97-103	Tools List	108-110
Food Service Countertops		Undermounting	
Heat Protection	90-91	Lavatory Bowls	53-54
Heat Ventilation	92	Kitchen Sinks	26-29
Hot/Cold Food Protection	93	Wainscoting/Walls	62-63
Hot Food Wells	89	Windowsills	70-71
Sneeze Guard	94		
Support Structures	89		
Hand Rails	65-69		
Heat Protection	27, 90-91		
Job Preparation	6		
Knee Wall Caps	72-74		

# EVERFORM® SOLID SURFACE FABRICATION GUIDE



## LIMITED WARRANTY

### EVERFORM® SOLID SURFACE — 10-YEAR LIMITED WARRANTY.

Everform® Solid Surface—10 Year Limited Warranty. Formica Corporation warrants to the original end-use purchaser that Formica Corporation will, at its option, repair or replace without charge, or refund the cost of Everform® Solid Surface, if the product fails solely due to a manufacturing defect within ten (10) years of the date of initial installation, subject to the exclusions set forth below. Repair or replacement during this 10-year period shall include reasonable labor charges needed to repair or replace the defective product, but shall not include the costs associated with removal, repair or replacement of fixtures, hardware or decorative treatments (such as floor, wall or ceiling treatments). During the entire 10-year warranty period, Formica Corporation's obligation as to repair or replacement shall further be limited to replacement or repair with colors and styles of products that are available at the time of replacement or repair. You may obtain coverage under this warranty by providing to Formica Corporation proof from the installer of the date of initial installation when you seek service. For service under this warranty, you must notify the dealer from whom you purchased the product or Formica Corporation in writing at the address below, providing your name and address, a description of the product involved and the nature of the defect. This warranty is transferable within the 10-year period only when the new owner submits to Formica Corporation (see address below) proof of the original date of installation. Transfer of the warranty entitles the new owner to coverage for the remainder of the 10-year warranty period. Everform® Solid Surface products must be stored, handled, installed, used and maintained in accordance with instructions provided by Formica Corporation. Copies of the Fabrication Guide and the Use & Care Guide for Everform® Solid Surface are available from your dealer or from Formica Corporation at the address listed below. You may also obtain these items by contacting Formica Corporation at 1-800-FORMICA™ or via Formica Corporation's website at [www.FORMICA.com](http://www.FORMICA.com).

### THIS WARRANTY DOES NOT COVER:

1. Conditions such as stains, scratches, water spots and burns.
2. Failure or dissatisfaction with joints or seams or of any adhesive, caulk or other accessory items.
3. Failure due to non-compliance with Formica Corporation's Fabrication Guide or Use & Care Guide for Everform® Solid Surface. Such failures include, but are not limited to, failures due to exposure to physical abuse (e.g., standing on countertops, impact by kitchen utensils), chemical abuse (e.g., harsh cleansers and solvents), thermal abuse (e.g., excessive heat from appliances) or misuse. Failures caused by fabrication techniques that do not conform to the approved techniques in the Fabrication Guide are the sole responsibility of the original fabricator/installer.
4. Use for purposes other than normal interior use.
5. Any products moved from their original place of installation and/or solid surfacing items not permanently attached to a substrate in a stationary position (e.g., table leaves, trivets, hinged covers).
6. Failures caused by settling of cabinets or substructure support, or failures caused by acts of nature.
7. Products installed with a known or visible manufacturing defect at the time of or prior to installation.
8. Color variations due to batch differences.
9. The condition of Everform® Solid Surface while being thermoformed or such material that is unsuccessfully thermoformed.

### LIMITED WARRANTY

Formica Corporation expressly warrants that, for a period of one (1) year from the date of first sale, these products will be reasonably free of defects in materials and workmanship, and that when properly handled and fabricated, will conform, within accepted tolerance, to applicable manufacturing specifications. Colors subject to dye lot variations. This limited warranty only applies to Formica Brand Laminate which is stored, handled, fabricated and installed in the manner recommended by Formica Corporation. Due to the variety of uses and applications to which Formica Brand Laminate may be put, FORMICA CORPORATION CAN MAKE NO WARRANTY THAT THIS PRODUCT IS SUITABLE FOR ANY PARTICULAR PURPOSE AND CAN MAKE NO OTHER WARRANTIES, EXPRESS OR IMPLIED, OTHER THAN THOSE SET FORTH ABOVE.

### DISCLAIMER OF WARRANTIES

THE WARRANTIES SET FORTH HEREIN OR IN FORMICA CORPORATION'S WARRANTY DOCUMENTS WITH RESPECT TO A PRODUCT ARE THE ONLY WARRANTIES MADE BY FORMICA CORPORATION IN CONNECTION WITH THESE PRODUCTS, AND ARE EXPRESSLY IN LIEU OF ANY OTHER WARRANTIES, EXPRESS OR IMPLIED, INCLUDING WITHOUT LIMITATION, ANY WARRANTY OF MERCHANTABILITY OR FITNESS FOR A PARTICULAR PURPOSE. PRODUCTS SOLD BY FORMICA CORPORATION ARE SOLD ONLY TO THE SPECIFICATIONS SPECIFICALLY SET FORTH BY FORMICA CORPORATION IN WRITING. FORMICA CORPORATION'S SOLE OBLIGATION FOR A REMEDY TO BUYER SHALL BE REPAIR OR REPLACEMENT OF NON-CONFORMING PRODUCTS, OR AT THE OPTION OF FORMICA CORPORATION, RETURN OF THE PRODUCT AND REFUND OF THE PURCHASE PRICE. BUYER ASSUMES ALL RISK WHATSOEVER AS TO THE RESULT OF THE USE OF THE PRODUCTS PURCHASED, WHETHER USED SINGLY OR IN COMBINATION WITH OTHER SUBSTANCES.

### LIMITATION OF LIABILITY

No claim by buyer of any kind, including claims for indemnification, whether as to quality or amount of products delivered or for non-delivery of products, shall be greater in amount than the purchase price of the products in respect of which damages are claimed. IN NO EVENT SHALL FORMICA CORPORATION BE LIABLE TO BUYER FOR ANY SPECIAL, INDIRECT, INCIDENTAL, RELIANCE, EXEMPLARY, OR CONSEQUENTIAL DAMAGES OR COVER, OR LOSS OF PROFIT, REVENUE OR USE, IN CONNECTION WITH, ARISING OUT OF, OR AS A RESULT OF, THE SALE, DELIVERY, SERVICING, USE OR LOSS OF USE OF THE PRODUCTS SOLD HEREUNDER, OR FOR ANY LIABILITY OF BUYER TO ANY THIRD PARTY WITH RESPECT THERETO. BUYER SHALL INSPECT FOR NONCONFORMITY PROMPTLY UPON RECEIPT. Failure by buyer to give Formica Corporation written notice of claim within 30 days from date of delivery or, in the case of non-delivery from the date fixed for delivery, shall constitute a waiver by buyer of all claims in respect of such products.





This limited warranty gives purchaser of Formica Brand Laminate specific legal rights. Other rights may be available and vary from state to state.

Any information or suggestion concerning application, specifications or compliances with codes and standards is provided solely for your convenient reference and without any representation as to accuracy or suitability. Formica Corporation disclaims any legal responsibility. The user must verify and test the suitability of any information or products for their own particular purpose of specific application.

### **MANUFACTURER**

Everform® Solid Surface products are toll manufactured in accordance with Formica Corporation's product specifications and quality requirements.

### **TECHNICAL SERVICES**

Technical assistance may be obtained through your local Formica® Brand Products Distributor or from Formica Corporation trained representatives in sales offices throughout the country. To assist these representatives, Formica Corporation maintains a sales and technical services staff in Cincinnati, Ohio. For technical assistance, contact your distributor or sales representative; write the company directly at Formica Corporation Technical Services Department, 10155 Reading Road, Cincinnati, OH, 45241; call (513) 786-3578 or 1-800-FORMICA™; or fax (513) 786-3195. In Canada, call 1-800-363-1405. In Mexico, call (525) 530-3135.

Formica is a sublicensed trademark to Formica Corporation. Formica and the Formica Anvil logo are registered trademarks of The Diller Corporation. 1-800-FORMICA and Everform are trademarks of The Diller Corporation. The products and manufacturing processes of Formica Corporation are protected under U.S. and foreign patents.

All ® brands are registered trademarks of the respective owners. All ™ brands are trademarks of the respective owners.

For warranty information, please visit [www.formica.com](http://www.formica.com) or call 1-800 -FORMICA™.

©2024 Formica Corporation  
Cincinnati, Ohio 45241